

**Shinbo**

2ch DIGITAL INDICATING CONTROLLER

WCS-13A

Indicating Controller

Dual  
unit functionality  
within  
**One** unit

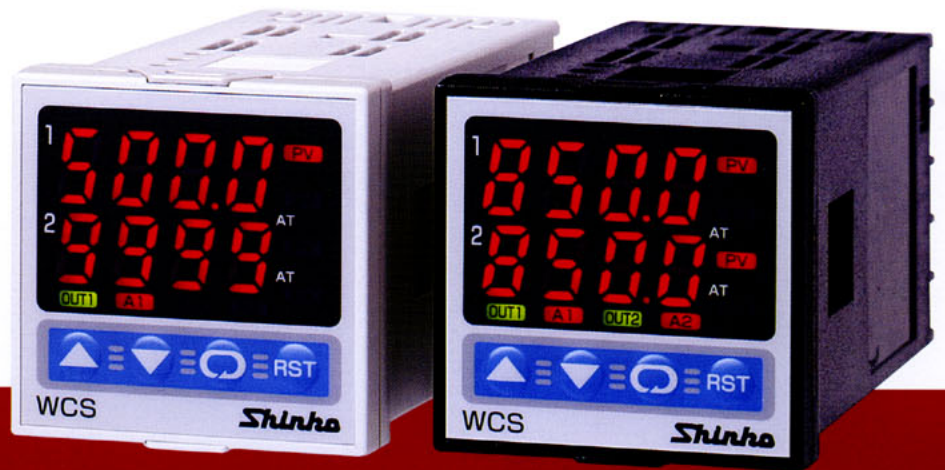

2-unit functions, **One** 48<sup>2</sup>mm unit integration  
**Controller + Timer**

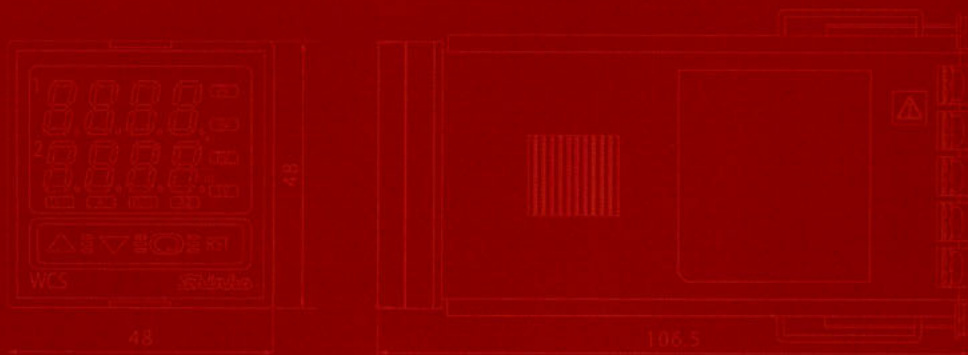

**Dual controller**

Reduce mounting space greatly via one unit usage.

## ■ Features

### ★ User defined combination

Controller+Timer, Dual controller

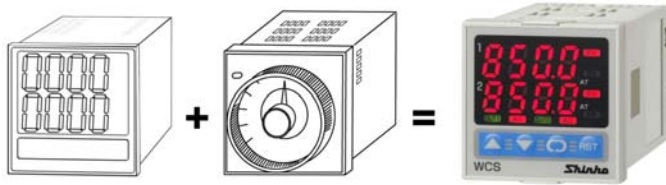

Controller + Timer

or . . .

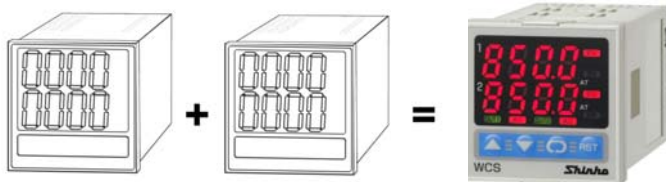

Controller + Controller

### ★ Save mounting space

As 2-unit functions can be used with a one unit, the mounting space can be reduced by half.

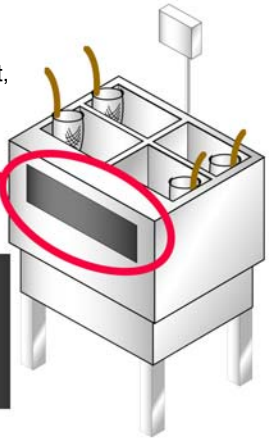
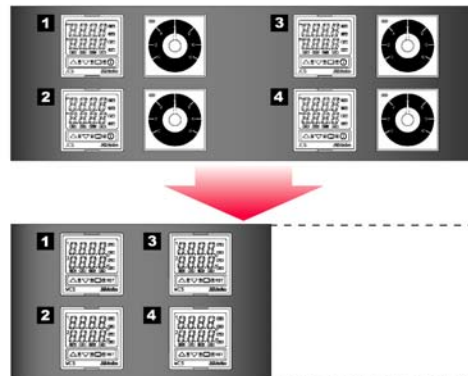

### ★ PV difference input function

Temperature difference between 2 points can be set and constantly maintained.

The heat source (heater) is controlled to maintain a constant temperature difference between 2 points(A, B). (e.g.) No condensation, defogging

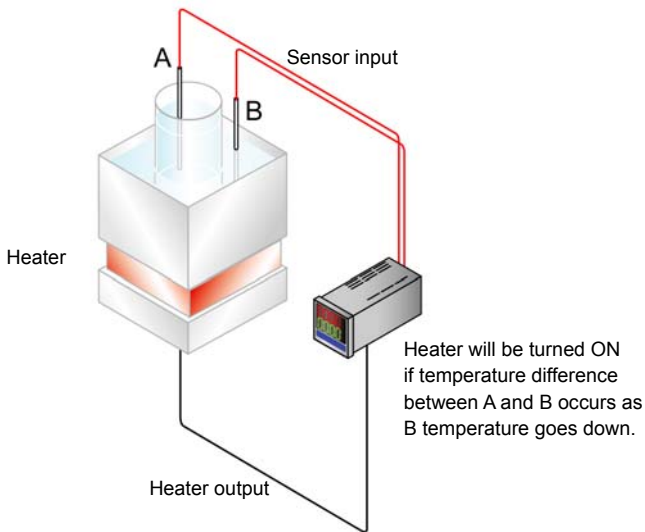

### ★CH2 function

The following functions are selectable.

- If CH2 is of Multi-range input (-M), DC voltage input (-V) or PV difference input (-S) spec  
CH2 controller (2-CH controller)  
CH1 output 2 (1-input, 2-output)  
CH1 cooling output (1-CH Heating/Cooling control output)  
CH1 transmission output (Effective when CH2 is DC current output type)  
CH1 timer
- If CH2 is based on delay timer (-T) spec  
Delay timer 1  
Delay timer 2

### ★ CH1 and CH2 Input/Output selection

Input/Output type can be selected for CH1 and CH2 respectively. (If CH2 is based on delay timer (-T) spec, CH2 output is not available)

#### [Input]

- Multi-range input:  
Thermocouple, RTD, DC current, and DC voltage (0 to 1 V DC) can be selected by keypad.
- DC voltage input:  
0 to 5V DC, 1 to 5V DC or 0 to 10V DC can be selected by keypad.
- Delay timer (\*)
- PV difference input: CH1 PV-CH2 PV=PV, Control is performed using the PV. (\*)

(\*): Available for CH2

#### [Control output]

- Relay contact: 1a
- Non-contact voltage (for SSR drive): 12V DC±15%
- DC current: 4 to 20mA DC

## ■ Model

WCS-1 3 A - □ □ / □ □ □ □ □ □ □ □		Series name: WCS-13A (W48 x H48mm)
Control action	3	PID
Alarm output	A	Alarm type can be selected by keypad. (*1)
CH1 control output	R	Relay contact: 1a
	S	Non-contact voltage (for SSR drive): 12V DC±15%
	A	DC current: 4 to 20mA DC
CH2 control output	R	Relay contact: 1a
	S	Non-contact voltage (for SSR drive): 12V DC±15%
	A	DC current: 4 to 20mA DC
	0	No control output as CH2 input is based on delay timer spec
CH1 input	M	Multi-range input (*2)
	V	DC voltage input (0 to 5V DC, 1 to 5V DC, 0 to 10V DC) (*3)
CH2 input	M	Multi-range input (2-CH controller) (*2)
	V	DC voltage input (0 to 5V DC, 1 to 5V DC, 0 to 10V DC) (2-CH controller) (*3)
	T	Delay timer (1-CH controller + Timer)
	S	PV difference input: CH1 PV-CH2 PV=PV, Control is performed using the PV. (1-CH controller)
Supply voltage	1	100 to 240V AC (standard)
		24V AC/DC (*4)
Option	BK	Color: Black
	TC	Terminal cover

(\*1): Alarm types (9 types and No alarm action) and Energized/De-energized can be selected by keypad.

(\*2): Thermocouple, RTD, DC current and DC voltage (only 0 to 1 V DC) can be selected by keypad.

(\*3): 0 to 5V DC, 1 to 5V DC or 0 to 10V DC can be selected by keypad.

(\*4): Supply voltage 100 to 240V AC is standard. When ordering 24V AC/DC, enter "1" after the input code.

**Input rated range**  
**Full multi-range input**

Input type		Input range		Input type		Input range	
Thermocouple	K	-200 to 1370°C	-320 to 2500°F	RTD	Pt100	-199.9 to 850.0°C	-199.9 to 999.9°F
	J	-199.9 to 400.0°C	-199.9 to 750.0°F			-200 to 850°C	-300 to 1500°F
	R	-200 to 1000°C	-320 to 1800°F		JPt100	-199.9 to 500.0°C	-199.9 to 900.0°F
	S	0 to 1760°C	0 to 3200°F			-200 to 500°C	-300 to 900°F
	B	0 to 1820°C	0 to 3300°F	DC current	4 to 20mA DC 0 to 20mA DC	-1999 to 9999	
	E	-200 to 800°C	-320 to 1500°F				
	T	-199.9 to 400.0°C	-199.9 to 750.0°F	DC voltage	0 to 1V DC		
	N	-200 to 1300°C	-320 to 2300°F				
	PL-II	0 to 1390°C	0 to 2500°F				
	C(W/Re5-26)	0 to 2315°C	0 to 4200°F				

**DC voltage input**

Input type	Input range
DC voltage	0 to 5V DC 1 to 5V DC 0 to 10V DC
	-1999 to 9999

- For the DC current and voltage input, scaling and decimal point place change are possible.
- For DC current input, connect 50Ω shunt resistor (sold separately) between input terminals.

**Standard specifications**

Display	CH1 PV/SV display Red 4 digits, Character size: 8×4mm (H x W) (The same as the CH2 PV/SV display)
Input	Thermocouple ---- K, J, R, S, B, E, T, N, PL-II, C (W/Re5-26) External resistance: 100Ω or less, however, for B input, 40Ω or less RTD ----- Pt100, JPt100 3-wire system (Allowable input lead wire resistance: 10Ω or less per wire) DC current ----- 0 to 20mA DC, 4 to 20mA DC: Input impedance: 50Ω (50Ω shunt resistor must be connected between input terminals.) Allowable input current: 50mA DC or less (when 50Ω shunt resistor is used) DC voltage ----- 0 to 1V DC: Input impedance 1MΩ or more Allowable input voltage: 5V DC or less, Allowable signal source resistance: 2kΩ or less 0 to 5V DC, 1 to 5V DC, 0 to 10V DC: Input impedance: 100kΩ or more, Allowable input voltage: 15V DC or less Allowable signal source resistance: 100Ω or less
Accuracy (Setting•Indication)	Thermocouple ----- Within ±0.2% of each input span±1digit, or within ±2°C (4°F), whichever is greater However, R, S input, the range is 0 to 200°C (0 to 400°F): Within ±6°C (12°F) B input, the range is 0 to 300°C (0 to 600°F): The accuracy is not guaranteed. K, J, E, T, N input, less than 0°C(32°F): Within ±0.4% of input span±1digit RTD ----- Within ±0.1% of each input span±1digit, or within ±1°C (2°F), whichever is greater DC current, voltage ----- Within ±0.2% of each input span±1digit
Input sampling period	0.5sec
CH1 timer function	Time accuracy: Within ±0.5% of the setting time
Control output (OUT)	Relay contact ----- 1a, control capacity: 3A 250V AC(resistive load), 1A 250V AC(inductive load cosφ=0.4), Electric life: 100,000 cycles Non-contact voltage ---- 12V DC±15% Max. 40mA DC (short circuit protected) DC current ----- 4 to 20mA DC load resistance: Max. 550Ω
Control action	The following actions can be selected by keypad. (Default: PID) PID (with auto-tuning function), PI, PD (with auto-reset function), P (with auto-reset function), ON/OFF OUT1 proportional band (P) --- 0 to 1000°C (2000°F), 0.0 to 999.9.0°C (°F) or 0.0 to 100.0% (ON/OFF action when set to 0 or 0.0) Integral time (I) ----- 0 to 1000sec (Off when set to 0) Derivative time (D) ----- 0 to 300sec (Off when set to 0) ARW ----- 0 to 100% Proportional cycle ----- 1 to 120sec (Not available for DC current output type) ON/OFF action hysteresis ---- 0.1 to 100.0°C(°F) or 1 to 1000 Output high limit ----- 0 to 100% (DC current: -5 to 105%) Output low limit ----- 0 to 100% (DC current: -5 to 105%)
Alarm output	Alarm types can be selected by keypad. (Default: No alarm action) • High limit alarm (Deviation setting) Setting range: -(Input span) to Input span • Low limit alarm (Deviation setting) Setting range: -(Input span) to Input span • High/Low limits alarm (Deviation setting) Setting range: 0 to Input span • High/Low limit range alarm (Deviation setting) Setting range: 0 to Input span • Process high alarm Setting range: Input range low limit to Input range high limit value • Process low alarm Setting range: Input range low limit to Input range high limit value • High limit alarm with standby (Deviation setting) Setting range: -(Input span) to Input span • Low limit alarm with standby (Deviation setting) Setting range: -(Input span) to Input span • High/Low limits alarm with standby (Deviation setting) Setting range: 0 to Input span For DC current or voltage input, the input span is the same as the scaling span. For DC current or voltage input, the input range low (or high) limit value is the same as the scaling low (or high) limit value. Setting accuracy ---- The same as the indication accuracy Action ----- ON/OFF action Hysteresis ----- Thermocouple, RTD input: 0.1 to 100.0°C(°F) DC current, voltage input: 1 to 1000 Output ----- Relay contact 1a, Control capacity: 3A 250V AC (Resistive load) Electric life: 100,000 cycles
Alarm 2 output	If CH1 cooling output is selected during CH2 function selection, CH1 will be OUT1 (Heating output) and CH2 will be OUT2 (Cooling output). OUT2 proportional band ----- 0.0 to 10.0 times OUT1 (CH1) proportional band (ON/OFF action when set to 0.0) OUT2 integral time ----- The same as that of OUT1 (CH1) OUT2 derivative time ----- The same as that of OUT1 (CH1) OUT2 proportional cycle ----- 1 to 120 seconds Overlap/Dead band ----- Thermocouple, RTD input: -100.0 to 100.0°C (°F) DC current, voltage input: -1000 to 1000 (The placement of the decimal point follows the selection) OUT2 ON/OFF action hysteresis -- Thermocouple, RTD input: 0.1 to 100.0°C(°F), DC current, voltage input: 1 to 1000 (The placement of the decimal point follows the selection) OUT2 high limit ----- 0 to 100% (DC current: -5 to 105%) OUT2 low limit ----- 0 to 100% (DC current: -5 to 105%) OUT2 action mode ----- Air cooling (linear characteristic), Oil cooling (1.5th power of the linear characteristic), Water cooling (2nd power of the linear characteristic). Selectable by keypads. Control output ----- Refer to the "Control output".
Delay timer	Between DI terminals Open: OFF, Between DI terminals Closed: ON, Circuit current when closed: 6mA
Transmission output	When CH1 transmission output (effective when CH2 is DC current output type) is selected during CH2 function selection, the value outputs in current, converting the value (PV, SV or MV) to an analog signal every 0.5 seconds. Resolution: 1/8192, Current: 4 to 20mA DC, Load resistance: Max. 550Ω, Output accuracy: Within±0.3% of Transmission output scaling span
Supply voltage	100 to 240V AC 50/60Hz, 24V AC/DC 50/60Hz Allowable voltage fluctuation range: 85 to 264V AC, 20 to 28V AC/DC
Power consumption	Approx. 8 VA
Insulation resistance	10MΩ or more, at 500V DC
Dielectric strength	Between Input terminal-Power terminal, Between Output terminal-Power terminal ---- 1.5kV AC for 1 minute

Environment	Ambient temperature: 0 to 50°C Ambient humidity: 35 to 85%RH (No condensation) Conforms to RoHS directive.
Case (Material, Color)	Material: Flame-resistant resin, Color: Light gray
Mounting	Flush (Mountable panel thickness: 1 to 8mm)
Setting	Sheet key input
Dimensions, Weight	External dimensions: W48×H48×D106.5mm Weight: Approx. 180g
Attached functions	Sensor correction, Set value lock, Power failure countermeasure, Self-diagnosis, Automatic cold junction temperature compensation (only for thermocouple), Burnout (overscale), Indication range, Control range, Warm-up indication, CH2 function selection
Accessories sold separately	50Ω Shunt resistor (for DC current input)

### Optional specifications

Please specify options according to users' needs. When ordering, specify an option code to be applied.

Color Black [BK]	Front panel frame and case: Black
Terminal cover [TC]	Electrical shock protection cover Be sure to use this terminal cover by adding this option if operator may touch the back of the controller while running the controller.

### External dimensions (Scale: mm)

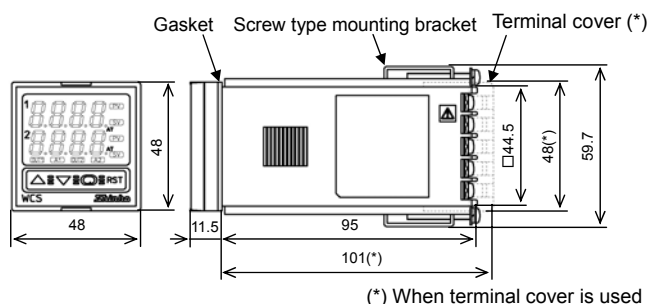

### Panel cutout (Scale: mm)

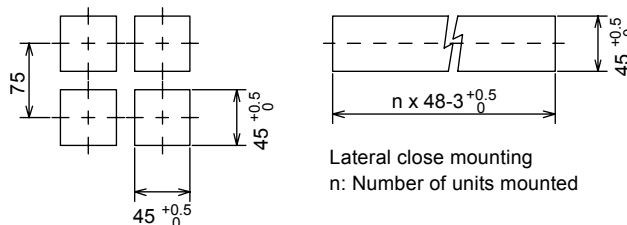

### Caution

If lateral close mounting is used for the controller, IP66 specification (Dust-proof/Drip-proof) may be compromised, and all warranties will be invalidated.

### Terminal arrangement

• If CH2 is of Multi-range input (-M), DC voltage input (-V) or PV difference input (-S) spec

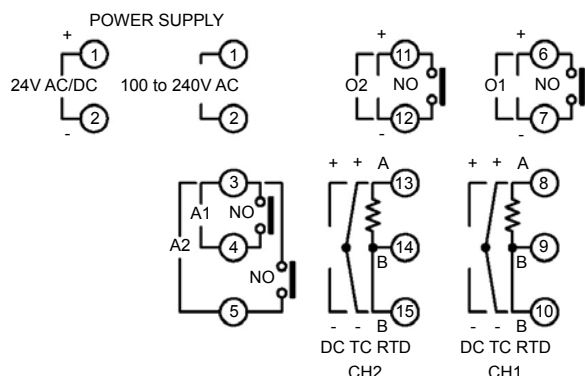

### Solderless terminal

Use a solderless terminal with an insulation sleeve in which the M3 screw fits.

Tightening torque should be approx. 0.63N•m.

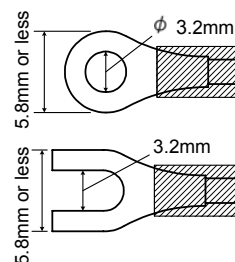

• If CH2 is based on delay timer (-T) spec

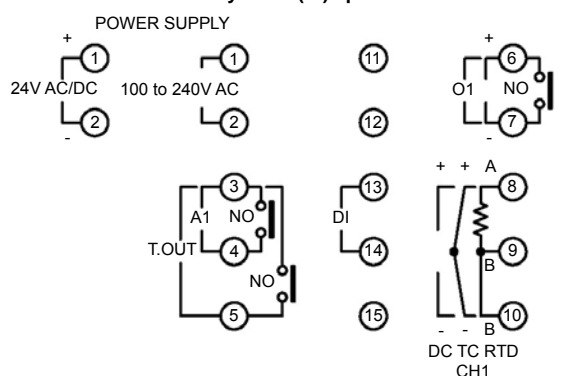

### Caution

- This controller does not have a built-in power switch, circuit breaker or fuse. It is necessary to install them near the controller.
- For a 24V AC/DC power source, do not confuse polarity when using direct current (DC).



- To ensure safe and correct use, thoroughly read and understand the manual before using this instrument.
- This instrument is intended to be used for industrial machinery, machine tools and measuring equipment. Verify correct usage after consulting purpose of use with our agency or main office. (Never use this instrument for medical purposes with which human lives are involved.)
- External protection devices such as protection equipment against excessive temperature rise, etc. must be installed, as malfunction of this product could result in serious damage to the system or injury to personnel. Also proper periodic maintenance is required.
- This instrument must be used under the conditions and environment described in the manual. Shinko Technos Co., Ltd. does not accept liability for any injury, loss of life or damage occurring due to the instrument being used under conditions not otherwise stated in the manual.

### Caution with respect to Export Trade Control Ordinance

To avoid this instrument from being used as a component in, or as being utilized in the manufacture of weapons of mass destruction (i.e. military applications, military equipment, etc.), please investigate the end users and the final use of this instrument. In the case of resale, ensure that this instrument is not illegally exported.



- This catalog is as of February 2008 and its contents are subject to change without notice.
- If you have any inquiries, please consult us or our agency.

## SHINKO TECHNOS CO., LTD. OVERSEAS DIVISION

Reg. Office : 2-5-1, Senbahigashi, Minoo, Osaka, 562-0035, Japan  
Tel : 81 - 72 - 727 - 6100  
Fax : 81 - 72 - 727 - 7006  
URL : <http://www.shinko-technos.co.jp>  
E-mail : [overseas@shinko-technos.co.jp](mailto:overseas@shinko-technos.co.jp)