

# COMBIMASS®

Gas analysis and gas flow measurement systems for portable and stationary operation

For the qualitative and quantitative analysis of biogas, sewage gas and landfill gas





## COMBIMASS® Gas analysis and gas flow measurement

For reliable and cost-effective operation, modern gas engines in biogas, sewage gas and landfill gas plants need a minimum gas quality, the monitoring and recording of which is usually demanded by the engine manufacturer and the plant's insurance. The monitoring of engine efficiency gives early warning of damage and helps to minimize it. Taking current gas consumption and gas generation into account permits optimized performance control.

Binder offers the perfect solution for these tasks – with **COMBIMASS®**. Inserting the portable analyzer **GA-m** into the **COMBIMASS® GA-s Docking station**, a stationary analyzer system with automatic sampling can be realized. In the stationary control system, **COMBIMASS® GA-s**, all the plant's gas flows and gas compositions are recorded, evaluated and documented. Flow measurement errors due to changing gas composition, humidity, pressure and temperature are compensated automatically.

The complete modular designed system **COMBIMASS® GA-s Click!** makes a much more flexible sampling possible, maintenance and service work become much more easier too. All correction possibilities of **COMBIMASS® flow meter** are available also in the **Click!** system.





# COMBIMASS®

## Gas analysis and gas flow measurement systems for portable and stationary operation

For decades now, Binder has been supplying leading plant manufacturers with innovative systems for industrial gas flow measurement.

In the last few years, the demand for reliable, precise and cost-effective measuring systems for biogas, sewage gas and landfill gas has increased significantly.

Since the composition of these gases changes over time, the linking of flow measurement and gas analysis provides great advantages:

- Always providing the most precise quantity measurement, even under changing conditions
- Cost advantages by avoiding the doubling up of components
- Attractive additional functions by linking the data from both systems

## The components of the modular COMBIMASS® concept are:

- **COMBIMASS® eco-bio+ SS:**  
Thermal dispersion gas flow meter, ATEX certified
- **COMBIMASS® eco-bio+ AL:**  
Thermal dispersion gas flow meter, for the operation in EX-Zone 2
- **COMBIMASS® GA-m:**  
Portable analyzer instrument, ATEX certified
- **COMBIMASS® GA-e:**  
Gas analyzer instrument, for stationary use only (picture at top left)
- **COMBIMASS® GA-s:**  
Docking station for gas analyzer GA-m and GA-e for fully automatic stationary operation (picture at left page)
- **COMBIMASS® GA-s Click!:**  
Flexible modular gas analyzer system for elevated requirements (picture at right)







### Special features of COMBIMASS® eco-bio+

- Compact and rugged sensor completely made of stainless steel
- Direct mass flow measurement based on thermal dispersion principle in standard m<sup>3</sup>/hr
- No temperature and pressure compensation necessary
- High accuracy even at low flow rates
- Different explosion-proof versions available
- Used for many years in sewage gas, landfill gas and biogas applications

### Special features of COMBIMASS® GA-m

- Measurement of up to 7 gas components using optical infrared analysis and long-life electrochemical cells
- Powerful sample pump
- Easy to exchange sample filter
- Up to 5 calibrated sensors can be inserted
- Battery pack, exchangeable in the field
- ATEX certified for operation in explosive environments; Zones 1 and 2
- Measurement of gas flow in Nm<sup>3</sup>/h with an optional COMBIMASS® flow sensor
- Measurement of gas temperature with an optional temperature sensor
- Internal data storage related to the sampling point, data transfer to the PC possible

### Special features of COMBIMASS® GA-s

- Multilingual menu, operation via touch screen or 6 keys
- Up to 2 sampling points supported, with automatically compensated mass flow measurement, even in the base model
- If desired, the precision of the gas analysis can be controlled automatically and held within an analysis accuracy tolerance
- The standardized pressure and temperature compensation of our gas flow meters, combined with automatic compensation of the gas concentration, represent a milestone for longterm stability and accuracy
- As an option, the water content and so the dry biogas flow can be calculated using a temperature sensor
- Measurements can be stored on local storage devices or data can be transferred using industrial standard communication to the PLC
- For data transfer we offer transmission via analog signal 4-20 mA as well as Ethernet Modbus TCP, worldwide known standard Modbus/RTU or Profibus DP
- Modular concept: Individual extensions and different gas analysis equipment are combined to create systems which fit customer's requirements

Gasanalysis display 1		Status	Sampling	0:1:54
- Sampling point +	CH4 %	Nm <sup>3</sup> /h	O2%	H2S ppm
0 digester 1	51.2	860	0.5	230.0
1 digester 2	52.1	973	0.5	126.0
2 collection pipe	52.2	954	0.6	187.0
3 CHP 1	52.4	481	0.6	7.0
5 CHP 2	52.4	473	0.6	11.0
Stop	<	Info	Menue	>
				Start

Sampling menu

Analog Input Item					
Name	Status	4-20mA	min	max	corr.
digester 1	x	x	0.00	25.00	1.00
temp. digester 1	x	x	0.00	100.00	1.00
digester 2	x	x	0.00	25.0	1.00
temp. digester 2	x	x	0.00	100.00	1.00
< Analysis Menue >					

Configuration menu of analog inputs

LAN				Modbus RTU	Modbus TCP	
IP Adress	10	1	1	231	Slave ID	2
Net Mask	255	255	255	0		
Gateway	0	0	0	0		
Please reset system after changing				Profibus DP		
				Slave ID	56	
				Menue		

Data transfer menu

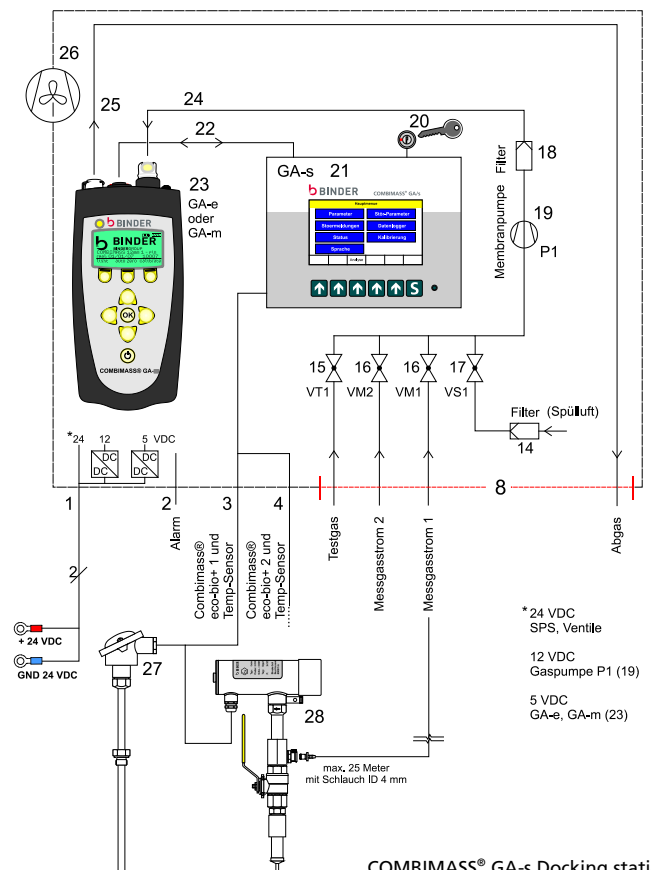

COMBIMASS® GA-s Docking station

## Special features of COMBIMASS® GA-s Click!

- Automatic analysis of up to 7 gas components, beside modules with standard operation ranges, further modules with extended ranges using heat conductivity can be supplied
- Analyzer station with automatic sampling for max. 10 sampling points
- All components are mounted into DIN-rail modules, which can be maintained easy at site
- Gas modules can be refurbished and used again
- Strong gas pump, easy changeable sample filters
- Flexible sampling sequence for each sampling point and splitting of gas ways inside the cabinet to achieve better accuracy
- Auto calibration check and auto calibration adjustment functions available
- Integration of **COMBIMASS® flow meter** in standard m<sup>3</sup>/hr and automatic correction of flow signal based on actual gas composition possible
- Possible integration of gas temperature probes for calculation of dry gas flow
- Data transfer to the local PLC using industrial standards (analog signal 4-20 mA, Ethernet Modbus TCP, Modbus RTU, Profibus DP and others on request)
- Data storage on a webserver with world-wide access to the data, alarms can be sent automatically by e-mail when pre-defined limits of concentrations are exceeded

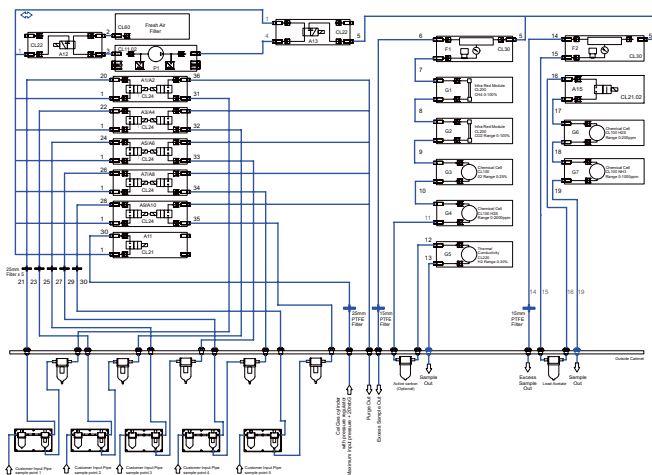

Example Gas flow scheme COMBIMASS® GA-s Click!





## CAMASS® Calibration technology for gas flow

Calibration is an important factor for success when using technologically advanced systems for measuring and controlling gases. In order to ensure the very highest measurement and control precision, each **COMBIMASS®** and **VACOMASS®** system is precisely calibrated in the **CAMASS®** calibration centre, using real operating conditions. In contrast to liquid media, the properties of flowing gases depend much more on operating conditions, gas composition and the actual flow conditions in the pipeline. If such parameters are not taken into account, considerable limitations must be expected regarding the accuracy of measurements.





# Guaranteed precision

## for COMBIMASS® and VACOMASS®

In order to guarantee the precision of the measurement and control systems, the pressure, temperature and loading conditions which will later occur in the customer's plant are simulated exactly using the appropriate gas mixture.

For difficult applications, even the corresponding pipeline configuration (up to nominal diameter DN 500) can be replicated exactly if necessary. In this way, every effect of flow on the measurement caused by the pipeline and the configuration can be recorded and compensated for.

## COMBIMASS® Flow conditioners

The patented **COMBIMASS® flow conditioners** are used for difficult pipeline configurations, after bends, cross-section changes, fittings or pulsating compressors.

They smoothen the flow profile, almost without pressure loss, ensuring reproducible conditions at the measuring location.

**COMBIMASS® flow conditioners** reduce the inlet and outflow straight pipe length for measurements to 3-7 times of the pipe diameter. They are rugged, dirt resistant and guarantee best measurement accuracy.

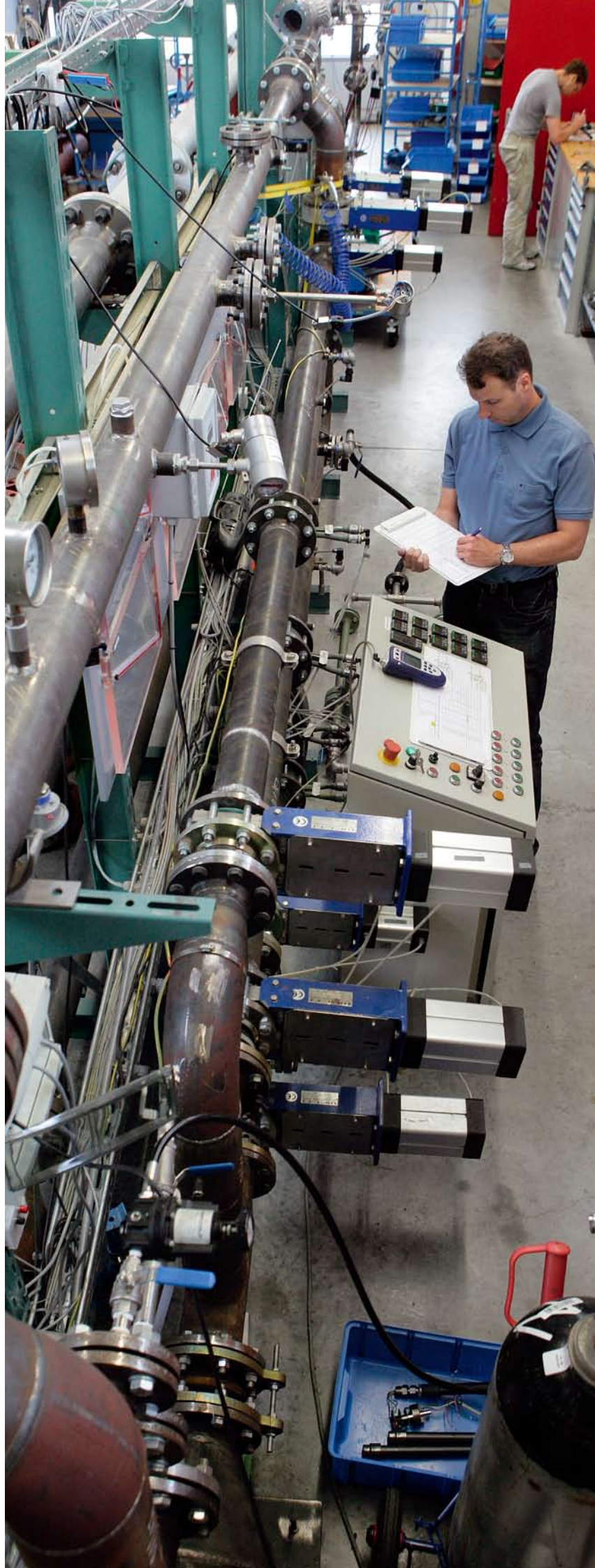
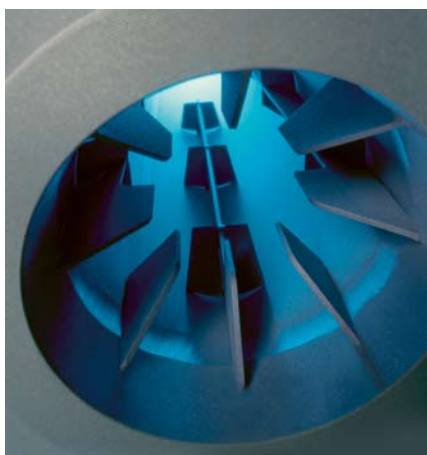



# Application areas for biogas

## Docking station for stationary applications

Modern biogas systems can hardly be operated in a cost-effective and environmentally friendly way without appropriate measurement and analysis technology.

A biogas analyzer is usually permanently installed in a combined heat and power plant container and the gas quantity released is also recorded in principle. But measurement errors due to varying gas pressure, temperature and composition are usually not taken into account. For the economic operation of biogas systems however, it is necessary to determine the gas composition and gas quantity of each individual fermenter.

While our **COMBIMASS® eco-bio+** thermal mass flow meters work reliably, accurately and almost without maintenance even under the most difficult conditions, a higher level of technical effort is needed for gas analysis equipment for long-term precision and reliability. This also affects the purchase price and maintenance costs. When using several gas analyzers, it is not just the above-mentioned costs that add up, but also the measurement uncertainty, so it becomes difficult to recognize a trend early.





# The latest technology

With our **COMBIMASS® GA-s** docking station, almost an unlimited number of sample points can be collected and evaluated.

Although the gas concentrations only change very slowly, the gas flow is subject to certain regular variations, caused, for example, by an agitator. For this reason it is useful to permanently install a **COMBIMASS® eco-bio+** thermal mass flow meter and connect it to the docking station.

For the gas quality, one current measurement per hour is completely sufficient. Here the individual sampling points can be connected to the docking station using small tubings. The sampling points are then switched in sequence via internal solenoid valves and evaluated in the processor.

It is also possible to only measure the gas quality automatically at the combined heat and power plant and use the mobile **COMBIMASS® GA-m** to record further measuring points. Here the portable gas analyzer **COMBIMASS® GA-m** can be removed during operation. Meanwhile the quantity measurements continue to run and are offset using the latest gas analysis values. As soon as the instrument is reconnected to the docking station after portable gas analysis, the new values are immediately read out from the data logger in the portable instrument and assigned to the appropriate measurement location.

## Advantages of portable/stationary gas analysis systems

- 100% system availability; even with extensive maintenance via plug and play exchange of the portable unit
- 100% operational reliability; even in winter – no frozen or blocked sampling pipes
- 50% cost saving; both stationary and portable analysis systems are needed in biogas and landfill systems. Maintenance costs are therefore halved. There are also significant cost advantages when purchasing
- 50% lower absolute measurement uncertainty; when 2 separate systems are used the measurement errors are summed
- 0% relative measurement uncertainty; when comparing stationary and portable measurements, there is no need to include an offset since the same measuring unit is used.





# The modular concept

## Unlimited freedom

The COMBIMASS® GA-s docking station can be combined with different gas analysis instruments

- **COMBIMASS® GA-m:**  
Self-sufficient portable gas analyzer with ATEX certification, battery operation, sample pump and data logger
- **COMBIMASS® GA-e:**  
Cost-effective, purely stationary gas analyzer, plug and play compatible, located in the same housing
- Third-party products can be connected via an analogue signal or a serial interface
- Can be operated wearing gloves: the most important queries can be made with only 6 easily operable keys. The relevant function is displayed directly above the key and corresponds to the current menu on the screen.

## The dry fermenter challenge

- A dozen sampling points for gas quantity and quality?  
No problem thanks to the unlimited scalability of the COMBIMASS® modular concept
- Thanks to automatic compensation, the highest measurement accuracy even for extremely variable gas composition
- The highest measurement accuracy, even for the lowest flows, without noticeable pressure loss.

## The biomethane challenge

The highest measurement accuracy for gas analysis. Automatic test measurements are carried out regularly with a test gas. Deviations from the set value determined in this way are recorded and compensated for.



# Application areas for sewage treatment plants

In contrast to biogas systems, the livelihood of a sewage treatment plant does not directly depend on the cost effectiveness of gas generation. Here there are other priorities. Since methane is many times more environmentally damaging than carbon dioxide, the fermentation process in the digester tower must be carried out in hermetically sealed conditions. Although in the past the biogas was often burnt off in a flare, with today's energy prices it is essential to make a profit from this free energy.

For reliable and cost-effective operation, modern gas engines in biogas, sewage gas and landfill gas systems need a minimum gas quality. Environmental regulations require modern and powerful gas measuring technology with appropriate data recording.

Alongside the highest operational reliability and ability to communicate, a high level of cost effectiveness is also indispensable. Usually stationary measurement systems are preferred here. Along with the quantity, these record and document the concentration of methane, hydrogen sulphide and oxygen in the digester gas.





# Special features in sewage treatment plants

Sewage treatment plants are often operated by wastewater treatment associations in large areas.

As well as large plants require the installation of stationary systems, there are numerous small sewage treatment plants. Here powerful, portable measurement systems are more cost-effective.

## **The COMBIMASS® concept offers both - stationary and portable measurement systems for better cost effectiveness in your sewage treatment plant**

- Portable components are compatible with stationary systems and usually interchangeable. A portable component can also be used in the case of plant maintenance.
- Competitive full maintenance at a fixed price, if desired with a free replacement unit while the maintenance or repair is being carried out.
- Very little training needed for the personnel. A uniform, ergonomic and clear operating philosophy makes expensive training unnecessary.
- Maximum user-friendliness via a sophisticated control concept
- Can be operated wearing gloves: the most important queries can be made with only 6 easily operable keys. The relevant function is displayed directly via a key in the local language and corresponds to the current menu on the screen.
- Future-proof: Requirements for extended compulsory documentation and data recording are to be expected. Today our systems are already fully equipped to deal with this. The data format is compatible with Excel, but can also optionally be exported in an essentially manipulation-proof binary format.
- Emergency operation: The **COMBIMASS®** concept provides optional battery supported operation. If the power supply fails, important alarm functions are ensured.









# For the highest demands

## **The COMBIMASS® concept is impressive in its flexibility and scalability**

In practice, the combination of our **COMBIMASS® GA-s docking station** with various gas analysis units proves to be very advantageous in a sewage treatment plant:

- **COMBIMASS® GA-e:**  
Low-cost measuring components for a purely stationary gas analysis system; measuring methane, oxygen and hydrogen sulphide.
- **COMBIMASS® GA-m:**  
Self-sufficient mobile gas analysis system with ATEX certification, battery operation, sample pump and data logger; the system is plug and play compatible and is accommodated in the same housing.
- **COMBIMASS® GA-s Click!:**  
Modular designed analyzer station with flexible sampling sequences.

## **Tried and tested a thousand times**

**COMBIMASS®** biogas and activation air measurements have proved themselves for many years in sewage treatment plants throughout the world and have matured into a standard.



# VACOMASS®

## Air supply system for biological sewage treatment plants

VACOMASS® is an integrated measurement and control system for the distribution of activation air, according to actual demand.

- It optimizes the biological degradation performance of your plant
- Helps to avoid breakdowns
- Ensures the process keeps within the limit values

VACOMASS® reduces your plant's energy costs and ensures cost effective operation.

### **A decisive factor is air supply according to actual demand**

Two thirds of the energy consumption of a sewage treatment plant are used to supply air to the activation basins. If too little air is supplied, the limit values in the effluent will be exceeded. But if too much air is supplied, the energy consumption is too high. During the 1980s, an oxygen supply of 2-5 mg per litre was normal. At the turn of this century, 2 mg/l was regarded as state-of-the-art. A modern plant can today be operated with 0.8 to 1.2 mg/l of oxygen. Such values can only be achieved with operational reliability using VACOMASS®. With VACOMASS®, the air supply can be controlled so precisely, that the oxygen concentration can be reduced to a minimum value without risk.

### **The VACOMASS® concept of locally controlled air supply**

The operating conditions in the biology of a sewage treatment plant are often not stable. The compressor pressure varies, the water level changes and the dynamic pressure loss in the pipe system varies depending on the speed of the air. But extensive action in the air distribution is needed to achieve minimal changes in pressure conditions. A problem which cannot be solved by conventional technology. This is precisely where the VACOMASS® concept of locally controlled air supply comes in. Each system recognizes the smallest shifts in pressure conditions and acts immediately by way of a precise iris diaphragm control valve. In this way, a regulated air supply according to the actual demand is always ensured.







# VACOMASS®

## A cost-effective concept

In many sewage treatment plants, using VACOMASS® can reduce energy costs by 15-30%, resulting in an investment payback period of only 1-3 years.

- VACOMASS® allows vibrations in the control circuit to be avoided. The aim is homogenous operation with high degradation performance.
- The oxygen concentration can be reduced by controlling the air supply precisely. Less activation air needs to be provided.
- Automatic control and adjustment of the pressure setpoint results in significant savings, e.g. when the plant is operating at partial load.
- VACOMASS® requires only slight pressure differences to control the air quantity accurately. This reduces the energy costs.
- All external disturbances resulting in static or dynamic pressure changes in the system are compensated for and do not influence performance. The operational reliability is increased.
- Gas tight closure of the iris diaphragm control valve improves the running of the process in alternating zone operation and reduces the risk of dirt contaminating the aerators considerably.
- Disturbances in the system, e.g. in the aerators, measurement probes or pressure supply, are registered during plausibility checks and action is taken without delay.
- The cyclic cleaning intervals for the aerators are adjustable. They help maintain low initial pressure loss and an extended operating life.

### A modular system solution from a one-stop shop – to the benefit of users and planning offices

- VACOMASS® is a system without application limitation.
- VACOMASS® measures, controls and, if necessary, closes the valve gas tight without inlet and outflow zones and so can be used at any point in a system.
- With its universal design, VACOMASS® simplifies planning, reduces installation sizes and replaces shut-off valves and control butterfly valves.
- VACOMASS® has a modular design. Depending on the requirements, system components can be used individually or in combination. System integration takes place via calibration in our CAMASS® calibration station, according to the actual operating conditions in the system.



# Application areas for landfill

Today hardly any new landfill sites are being created; waste incineration, recycling and avoiding creating waste in the first place are the clear fashion. All the same, high-quality gas measurement technology is needed here too.

The landfill gas is used energetically during the stable anaerobic methane phase. The same metrological requirements are valid for the operation of the gas engine as for biogas and sewage treatment plants: For reliable and cost-effective operation, modern gas engines need a minimum gas quality, the monitoring and recording of which is usually demanded by the engine manufacturer and the plant's insurance.

The monitoring of motor efficiency gives early warning of damage and helps to minimize it. Taking current gas consumption and gas generation into account permits optimized performance control.

**Binder offers the perfect solution for these tasks – with the modular COMBIMASS® concept.**

In the stationary control COMBIMASS® GA-s, gas consumption and gas composition are recorded, evaluated and documented. Measurement errors due to changing gas composition, humidity, pressure and temperature are compensated for automatically.

The landfill gas is captured in multiple wells, collected in compressor stations and guided to the generator. Each of the compressor stations needs a stationary measurement system for gas composition and gas quantity. The connected wells are frequently scanned and the data saved. Due to the enormous areas involved, it is not economical or safe to connect the individual wells permanently for fully automatic monitoring. The only meaningful solution is to monitor the wells using portable technology.

**Binder's COMBIMASS® concept is also excellently suited for this application.**







# COMBIMASS® GA-m COMBIMASS® GA-s COMBIMASS® eco-bio+

## **Portable and stationary landfill gas analysis and portable and stationary gas flow measurement**

The COMBIMASS® GA-m is removed from the docking station, whereby the permanently connected flow meter COMBIMASS® eco-bio+ continues to record the gas measurements and compensates with the latest gas composition.

The portable flow meter is then connected to the communication port... The COMBIMASS® eco-bio+ is operated by main power supply or via a 12 V battery outside the safety zone.

The formation of landfill gas and the gas composition for each individual well is then recorded and saved with the touch of a button in the COMBIMASS® GA-m, including sample location ID, date and time of measuring. A half inch ball valve connects the COMBIMASS® eco-bio+ gas flow meter to the gas pipeline; the gas composition is measured simultaneously via a T-piece.

When the tour is completed, the portable unit can be reconnected to the docking station and the measurement values transferred.

## **Comprehensive series communication interfaces**

The individual docking stations are linked to each other and also communicate with the central processing system. As well as the standard Ethernet Modbus TCP and Modbus RTU data transfer, further commercially available gateways, (e.g. Profibus) or wireless modems (e.g. W-LAN or GSM) can also be used. In this way, several hundred sampling points can be monitored and documented with least effort and the highest level of operational reliability.

Even in older landfill sites, where the landfill gas is no longer used energetically during the decaying methane phase and is only burnt off in a flare, environmental protection regulations require a further monitoring.







# COMBIMASS®

## A convincing concept

**The COMBIMASS® concept is optimal if the following properties are important to you:**

- Precise gas quantity measurement without pressure loss
  - Precise gas quantity measurement for very small flows
  - Precise gas quantity measurement with a large measuring range
  - Precise gas quantity measurement even with variable gas composition
  - Precise gas quantity measurement, almost no maintenance needed, portable and stationary use, at a reasonable price.
- 
- Precise gas analysis, very little maintenance needed, portable and stationary use, at a reasonable price
  - Precise gas analysis, with full maintenance and an exchange unit for 100% availability at a reasonable fixed price
  - High-performance stationary analysis system with the highest level of precision, scalable, with flow measurement and humidity compensation, low maintenance, with independent measurement data recording and various data transfer possibilities or local data storage – all at a reasonable price

**For all system operators with high demands who don't have money to waste!**



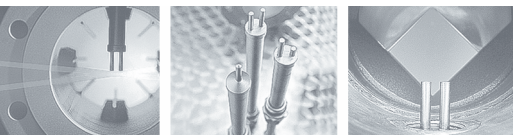

## LOCAL DISTRIBUTOR

---

## PRODUCTION

## DISTRIBUTION

---

### **BINDER GmbH**

Buchbrunnenweg 18  
89081 Ulm, Germany  
Tel +49 731 18998-0  
Fax +49 731 18998-88  
info@bindergroup.info  
www.bindergroup.info

### **INSTRUM AG**

Waldeckstrasse 100  
4127 Birsfelden, Switzerland  
Tel +41 61 3121136  
Fax +41 61 3121126  
info@instrum.ch  
www.instrum.ch

### **BETA BV**

Verrijn Stuartlaan 22  
2288 EL Rijswijk  
The Netherlands  
Tel +31 70 3199700  
Fax +31 70 3199790  
info@beta-b.nl  
www.beta-b.nl

### **Binder Engineering GmbH**

Buchbrunnenweg 18  
89081 Ulm, Germany  
Tel +49 731 96826-0  
Fax +49 731 96826-99  
info@bindergroup.info  
www.bindergroup.info

### **Binder Engineering AG**

Waldeckstrasse 100  
4127 Birsfelden, Switzerland  
Tel +41 61 3199130  
Fax +41 61 3199134  
info@bindergroup.info  
www.bindergroup.info

### **Binder Engineering BV**

Verrijn Stuartlaan 22  
2288 EL Rijswijk  
The Netherlands  
Tel +31 70 3074300  
Fax +31 70 3074399  
sales@binder-engineering.nl  
www.bindergroup.info

### **Binder Engineering NV**

Bergensesteenweg 709 A  
1600 Sint-Pieters-Leeuw  
Belgium  
Tel +32 2 3000795  
Fax +32 2 3000797  
info@binder-engineering.be  
www.bindergroup.info

### **Binder Engineering SAS**

41, Place Jules Ferry  
92120 Montrouge, France  
Tel +33 1 46120445  
Fax +33 1 46120442  
binder@mesa.fr  
www.bindergroup.info

### **Binder Instrumentation Pte Ltd**

25 International Business Park  
# 04-06 German Centre  
Singapore 609916  
Tel +65 6 5627637  
Fax +65 6 5627638  
binder.engrg@pacific.net.sg  
www.bindergroup.info

### **Binder Instrumentation Trading (Shanghai) Co., Ltd**

Room 106A  
Xingyuan Tech Building  
Guiping Road 418  
Shanghai, P.R. China, 200233  
Tel +86 21 64959889  
Fax +86 21 64959887  
info@binder-instrumentation.cn  
www.bindergroup.info

Please visit our website for more  
information and distribution in  
other countries:  
[www.bindergroup.info](http://www.bindergroup.info)

Please contact the company with  
the address shown in red or the  
local distributor.