

INTRODUCTION

TxBlock is a fully customer programmable head mount temperature transmitter.

In-the-field configuration of input type and working range can be achieved by means of a cable and an RS232 port from a PC.

TxRail represents the utmost technology in DIN rail mount temperature transmitters.

Input type, working range and output calibration can be achieved by means of a cable and an RS232 port from a PC.

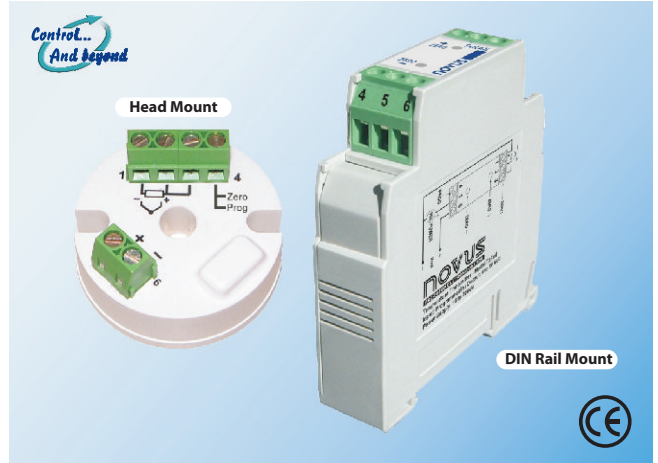

FEATURES

TxBlock and **TxRail** comprehends a family of head mount and DIN rail mount 4-20mA temperature transmitters for the most common temperature applications.

One single model can be configured to accept several thermocouple types and Pt100 RTDs.

SPECIFICATIONS

- Programmable input: thermocouples type J, K, T, E, N, R, S, and Pt100 RTD with programmable working range
- 2-wire loop powered 4-20 mA output
- Linearized 4 to 20 mA or 20 to 4 mA output for t/c and Pt100
- Cold junction compensation for thermocouples
- Optional 0 to 10Vdc for **TxRail** only
- 2 or 3-wire Pt100 with linearization
- Windows configurator (optional)
- Configuration with a PC via **TxConfig** interface
- Manual zero (offset) adjustment can be done by means of a wire jumper simulating a keyboard for the **TxBlock** or with 2 front keys in the **TxRail**
- Digital filter can be set for best 50 or 60 Hz performance
- Power supply: 12 to 30Vdc
- Accuracy: Pt100 and 0 to 50 mV ±0.2% full scale. Thermocouples ±0.3% max. of full scale
- Temperature effect: 0.003% SPAN/°C
- Working temperature: -40 to +85 °C (-40 to 185 °F)
- Sensor failure protection: programmable burnout upscale or downscale
- Dimensions: **TxBlock**: 44 mm (Diam.) x 25 mm (H including bornes). **TxRail**: 72 mm (H) x 78 mm (D) x 19 mm (W)

CONFIGURATION

TxBlock and **TxRail** configuration is performed by using the **TxConfig** software and **TxConfig USB** interface connected to the PC.

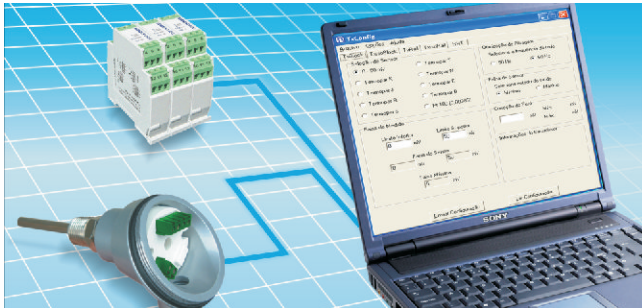

TEMPERATURE TRANSMITTER

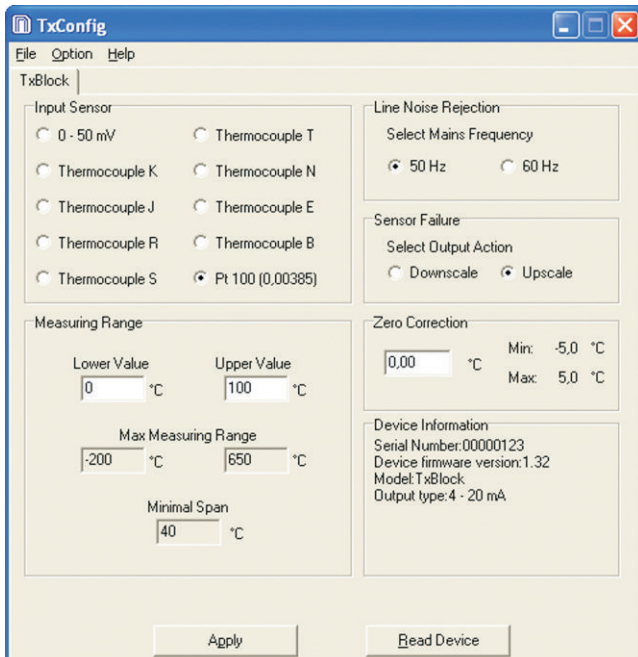

CONFIGURATION from the PC

INPUT TYPES AND RANGES

User can easily program input type and temperature range as below:

INPUT	RANGE	MIN SPAN
Thermocouple K	0 to 1370 °C / 32 to 2500 °F	100 °C
Thermocouple J	0 to 760 °C / 32 to 1400 °F	100 °C
Thermocouple R	0 to 1760 °C / 32 to 3200 °F	400 °C
Thermocouple S	0 to 1760 °C / 32 to 3200 °F	400 °C
Thermocouple T	0 to 400 °C / 32 to 752 °F	100 °C
Thermocouple N	0 to 1300 °C / 32 to 2372 °F	100 °C
Thermocouple E	0 to 720 °C / 32 to 1328 °F	100 °C
Pt100	-200 to 650 °C / -328 to 1202 °F	40 °C
Voltage	0 to 50 mV	5 mV

TxConfig CONNECTIONS

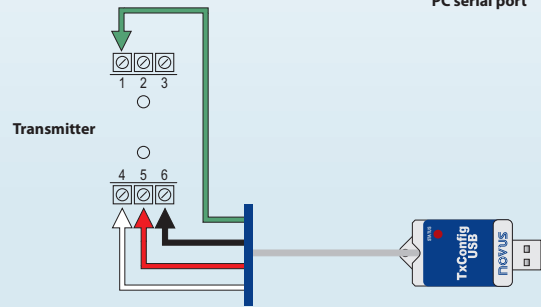
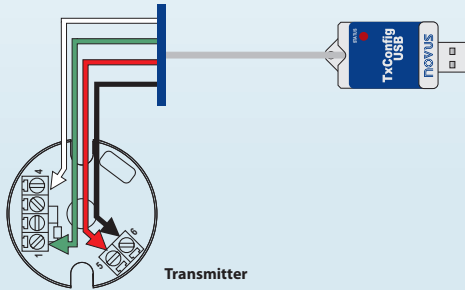
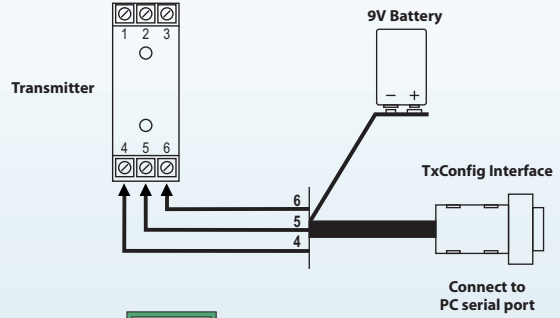
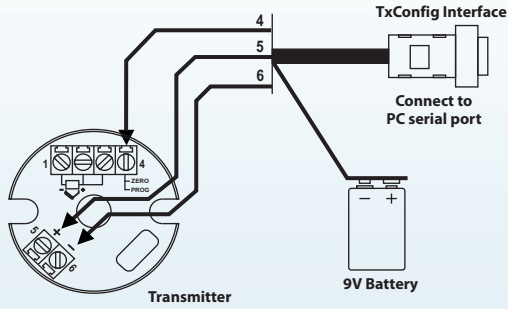

LOAD & POWER SUPPLY

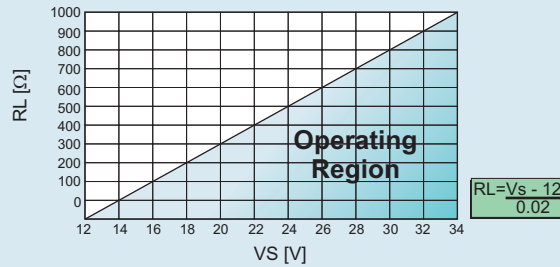

ELECTRICAL CONNECTIONS

Pt100

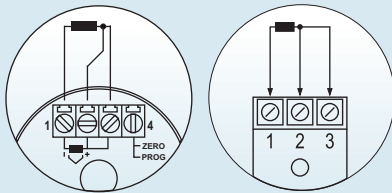

Thermocouple

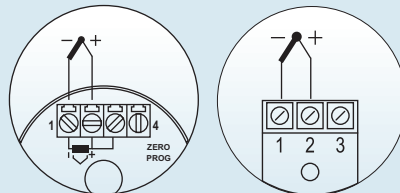

Output

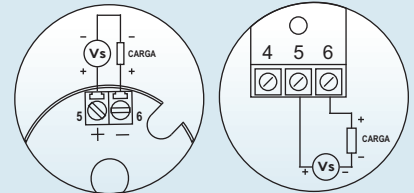

DIMENSIONS

TxBlock

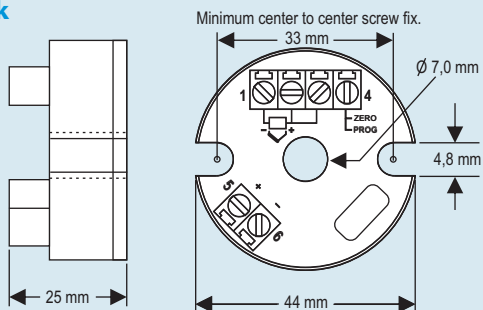

TxRail

