

## INTRODUCTION

The **RHT-WM** and **RHT-DM** transmitter series incorporate the best high accuracy and great stability relative humidity and temperature sensors. They convert the measured values into linear 4 to 20 mA signals and optional 0 to 10 Vdc output can also be offered under request.

The microprocessor based circuit enables full configuration of output range when used with the **TxConfig** PC interface and the Windows® based software.

The humidity signal can be configured to either relative humidity or dew point output.

The **RHT-WM** model is dedicated to wall mounted applications and the **RHT-DM** version is suitable for duct and through-the-wall applications.

Control...  
And beyond

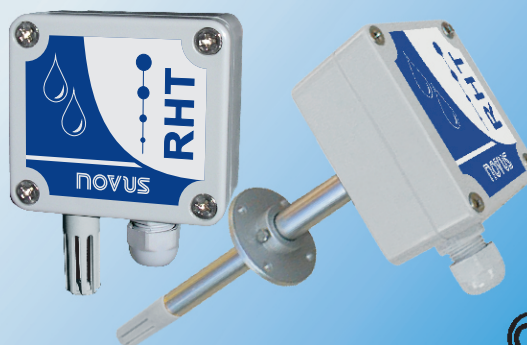

## FEATURES & SPECIFICATIONS

### Humidity Transmitter

- Output resolution: 0.022 mA (4-20 mA) or 0.015 V (0-10 V)
- Accuracy: refer to diagram
- Repetibility:  $\pm 1\%RH$
- Hysteresis:  $\pm 1\%RH$
- Non-linearity:  $<< 1\%RH$
- Stability:  $< 1\%RH$  per year
- Range: programmable anywhere from 0 to 100%RH or from  $-100$  and  $103$  °C for dew point
- Response Time: 4 s in fairly still air

### Temperature Transmitter

- Output resolution: 0.006 mA (4-20 mA) or 0.003 V (0-10 V)
- Accuracy: refer to diagram
- Repetibility:  $\pm 0.1^\circ C$
- Range: programmable between  $-40$  and  $120$  °C
- Response time: up to 30 s in fairly still air

### General Features

- Power: from 12 Vdc to 30 Vdc (model 4-20 mA) or 18 to 30 Vdc (model 0-10 V)
- Output:
  - Two-wire loop powered 4-20 mA or 20-4 mA
  - Voltage output: 0-10 Vdc (optional)
- Isolation between outputs:
  - Isolated 4-20 mA outputs
  - Non-isolated 0-10 Vdc outputs
- Output load (RL):
  - Model 4-20 mA:  $RL \text{ (max. in Ohms)} = (Vdc - 12) / 0.02$ , where: Vdc=power voltage in Volts
  - Model 0-10Vdc: 10 Kohms Minimum
- Internal protection against reversed voltage wire polarity
- Cable input: PG7 cable gland
- Operational Limits:
  - Sensor and Probe (RHT-DM): refer to diagram below
  - Electronic Module:  $-10$  to  $+65$  °C, 0 to 95%RH

## Measuring Accuracy and Sensor Operational Limits

### Relative Humidity Accuracy @25 °C

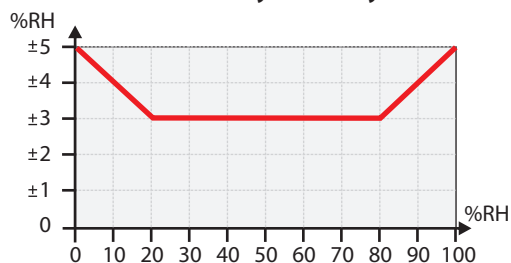

### Temperature Accuracy

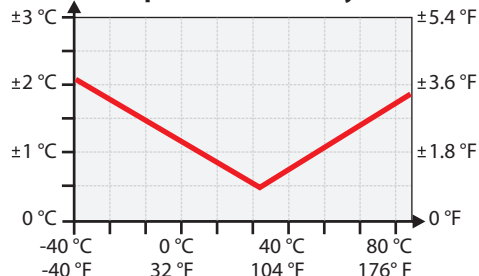

### Dew Point Accuracy @25 °C

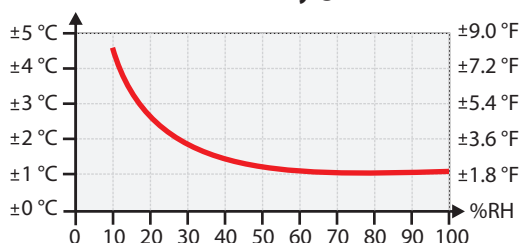

### RH Sensor Operating Conditions

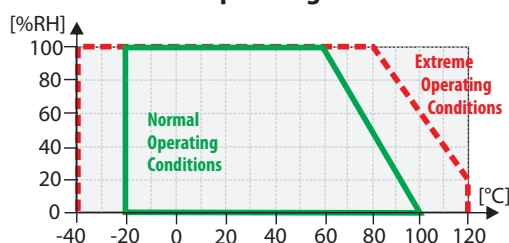

The RH sensor used in the equipment may be damaged or descalibrated when exposed to contaminated atmospheres or chemical agents. Hydrochloric, nitrous or sulphuric acid or ammonia in high concentrations may damage the sensor. Acetone, ethanol and propylene glycol may cause reversible measuring errors.

CONFIGURATION

RHT-WM and RHT-DM configuration is performed by using the TxConfig software and interface which is connected to the PC.

With the configuration one can set the transmitted output range, correct measuring deviations (zero correction) and choose sensor failure conditions (upscale or downscale). Sensor internal information as serial number, product version and model can be also be digitally presented in the programming software menu.

The factory default settings are:

- Humidity measuring range: 0 to 100%
- Temperature measuring range: 0 to 100°C
- Upscale signal outputs when sensor break or failure

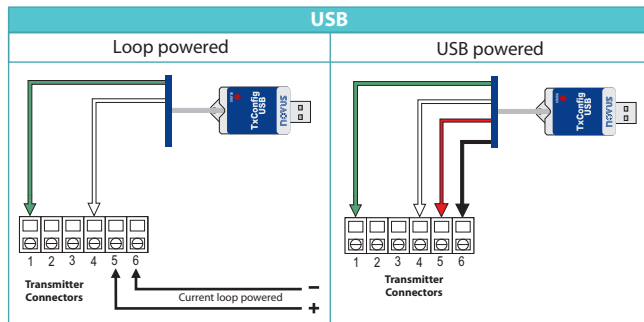
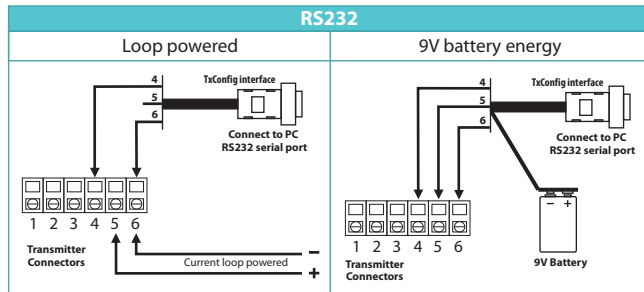

TxConfig Interface Connections

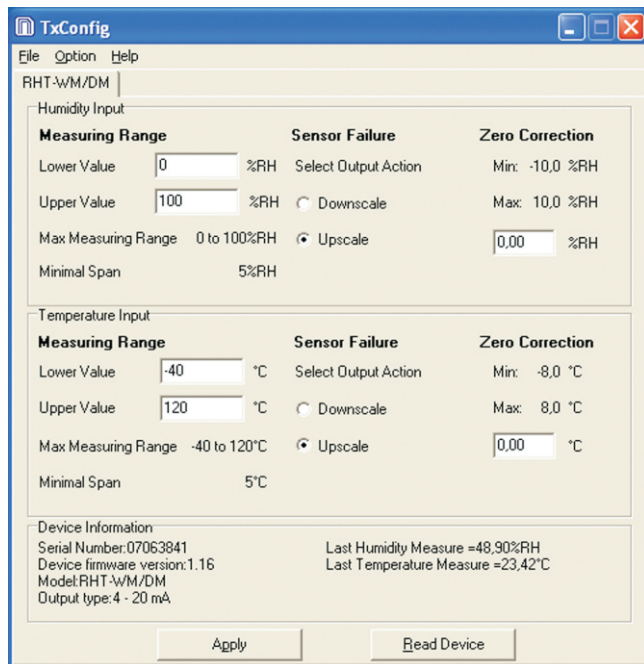

TxConfig software main prompt

ELECTRICAL CONNECTIONS

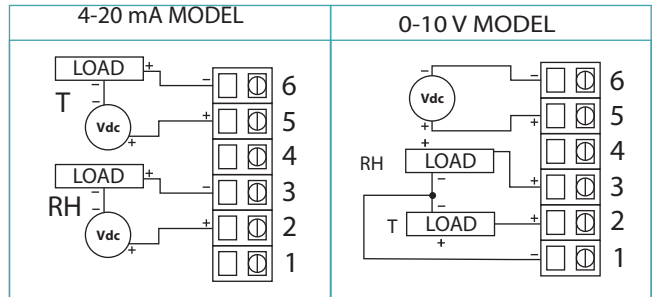

Load - represents a measuring instrument (indicator, controller, recorder, etc.).

INSTALLATION

RHT-WM model

This compact electronic module performs fast and accurate measurements and isolates the sensor from internal module self heating. The sensor probe must be installed facing down.

Remove the four module cover screws to access the electrical terminal connectors and the two wall mounting fixing holes.

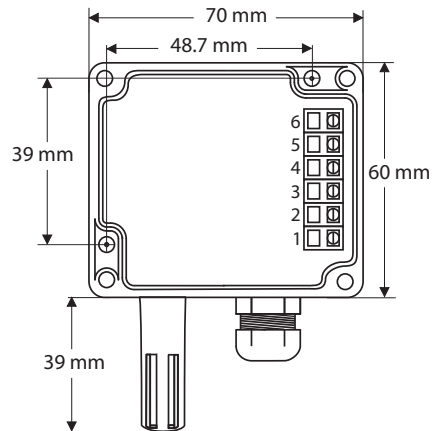

RHT-DM model

Sharing the same case and electronics as the RHT-WM module, the RHT-DM holds the sensor at the tip of a 150, 250 or 400 mm stainless steel sheath. A plastic flanged fixture is part of the unit.

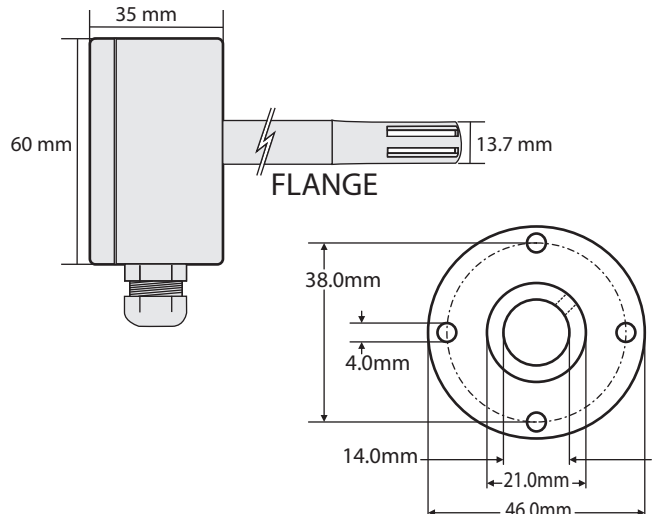

TEMPERATURE & RELATIVE HUMIDITY TRANSMITTERS