

## INTRODUCTION

### PRINCIPLE

The RP series operating principle is simple. A unit is usually located through a bin wall at the top, middle or low level of a bin. During normal operation (no material present) a synchronous motor rotates the paddle at 1 RPM. When this paddle rotation is impeded by material, surrounding the paddle, motor will stall and cause the Micro switch to change state. (indicating an alarm or control)

### APPLICATIONS

Suitable for powdery producing & processing industries such as plastic, chemical, medical, forage, cement and fertilizer powders.

### STRUCTURE

### FEATURES

- ★ Airtight sealing device, outdoor application is available.
- ★ Unique sealing ring design, it can perform good dust protection to avoid the dust permeate into housing body along with the shaft.
- ★ The torque force is adjustable.
- ★ The performance of torsion is stable and reliable.
- ★ If the rotary paddle bears an extra overload, the motor will be appeared slide to prevent the inside mechanism damaged.
- ★ It is rationally designed, the inside mechanisms are easily tore down for checking, maintenance and replacement. It doesn't necessary to remove the complete set from the tank.

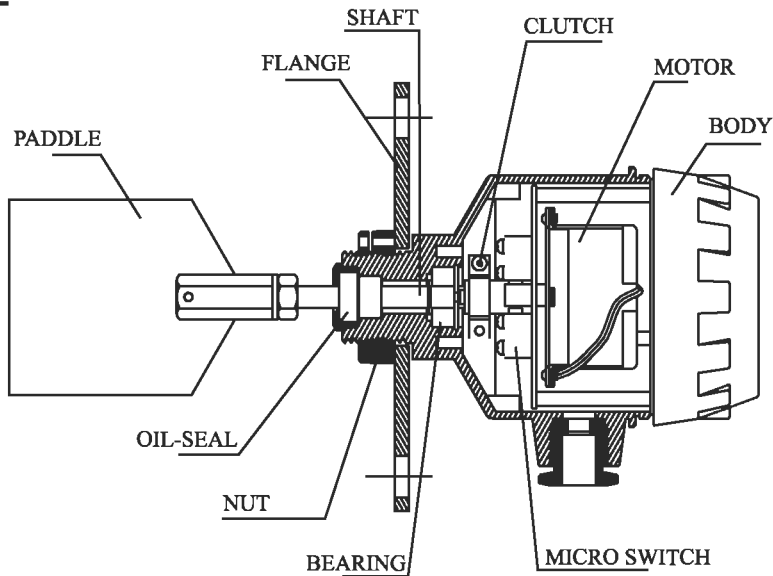

PADDLE TYPE LEVEL SENSOR

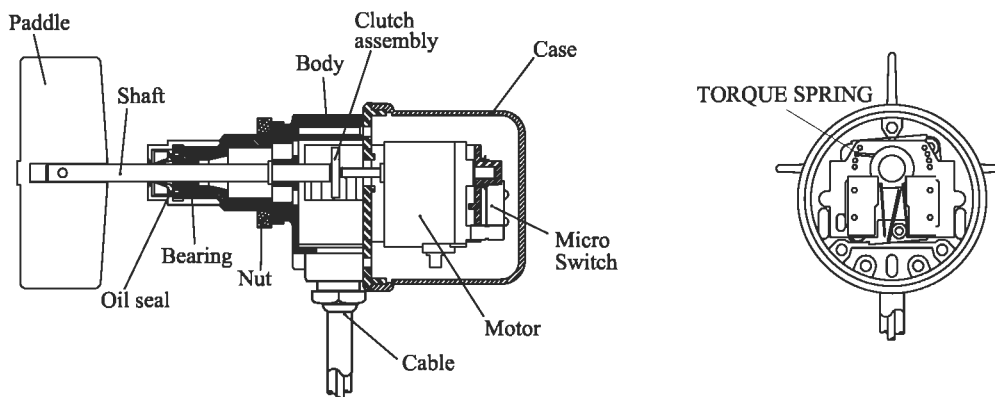

MINI PADDLE TYPE LEVEL SENSOR

# INTRODUCTION

## CONTROL SWITCH DEVICES WORKING PRINCIPLE

1. When the synchronous motor is turning. It means that material isn't touching the paddles, the (C.L) stands for "terminal point connected".
2. When material is touching the paddles, (C.L) stands for "cut-off", (C.H) stands for "connected" the synchronous motor's current is to be cut off.
3. When the material drops away from the paddles, the synchronous motor runs again and the terminal point is connected, (C.L) show that the cycle has begun again.

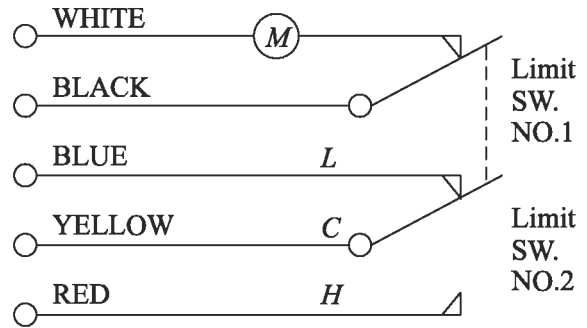

## TORQUE ADJUSTING MECHANISM

The torque spring is applied to adjust the shaft output torque force, which is set at "weak" position at factory side, it is adjustable as per customer side target measuring material S.G. (special gravity), if the measured material with higher S.G., please try to release it to more

stronger spring force position step until you found the proper orientation. The paddle sensitivity will be interacted by more weaker, otherwise, the low S.G. material will release torque spring to the weakest position, which will cause the paddle performance to be more sensitive.

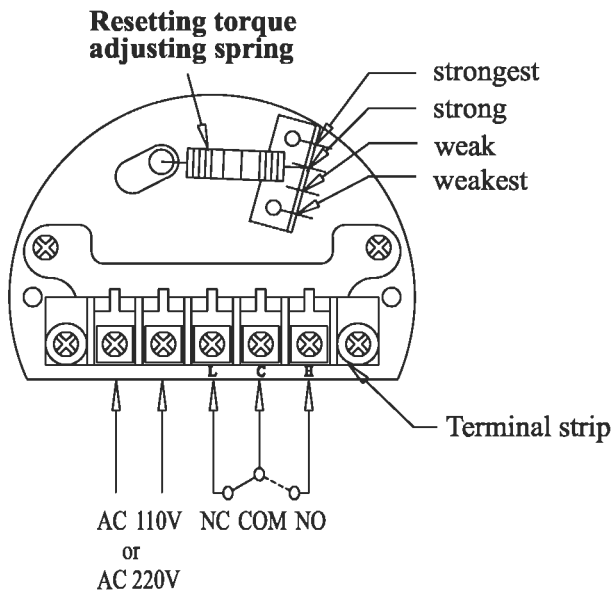

Available: SE110, 120, 130, 140, 160, 170

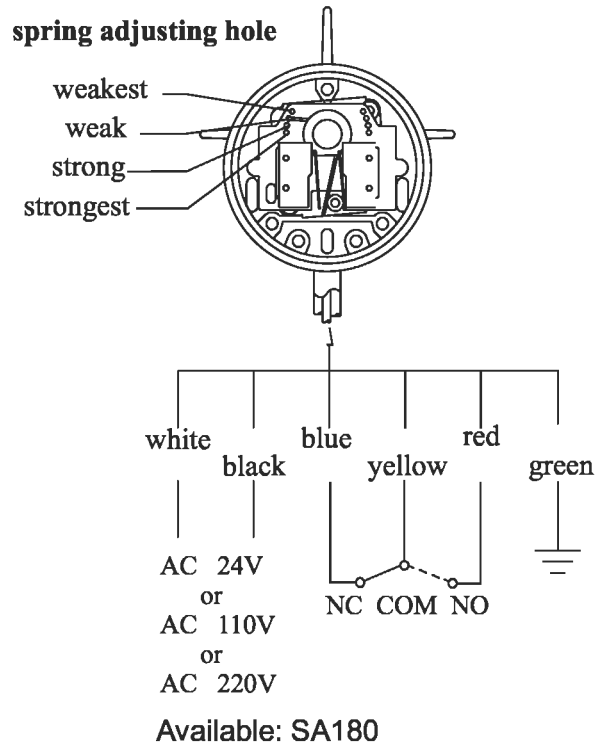

Available: SA180

# STANDARD SPECIFICATION

- Power source : A-110VAC, B-220VAC, C-240VAC, 50/60Hz
- Power consumption : 3W
- Contact capacity : SPDT, 5A/250VAC
- Rotary speed : 1 R.P.M.
- Insulation test voltage : AC 1500V × 1minute

- Torque : 0.5 ~1.0 kg-cm
- Connect : 1"PF screw or JIS 2-1/2" × 5kg/cm<sup>2</sup> flange
- Protection/ material : IP65 / ADC-12
- Conduit : 1/2"PF
- Specific gravity : 0.5g/cm<sup>3</sup> (30Lb/ft<sup>3</sup>)

## SE110A/B/C SCREW TYPE

- Horizontal mounting
- Temp. (-10°C ~ 70°C)
- Weight: 1.2 kg

SE110A/B/C

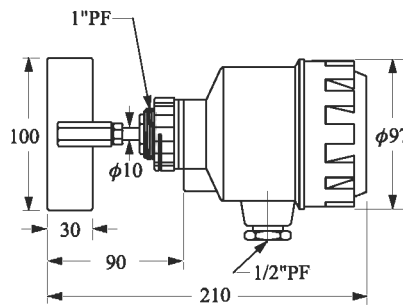

SE111A/B/C

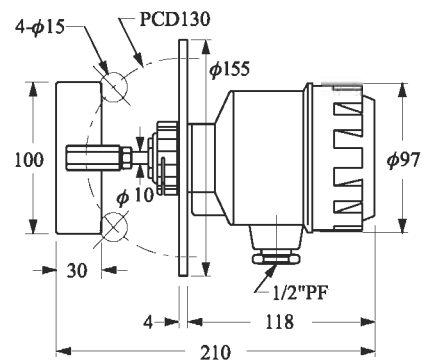

## RP111A/B/C FLANGE TYPE

- Horizontal mounting
- Temp. (-10°C ~ 70°C)
- Weight: 1.7 kg

## SE120A/B/C SHAFT PROTECTIVE TUBE TYPE

- Horizontal /Vertical mounting
- Temp. (-10°C ~ 70°C)
- Weight: 1.2 kg
- The whole section from flange to paddle are made of SUS 304
- Standard Length (option):  
L--250mm (2.2 kg)  
L--500mm (2.5 kg)  
L--750mm (2.8 kg)
- Special length is made by order

SE120A/B/C

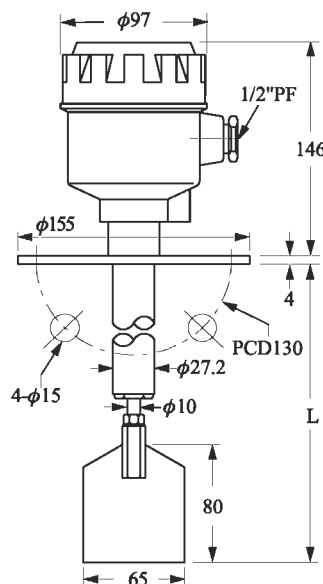

SE130A/B/C

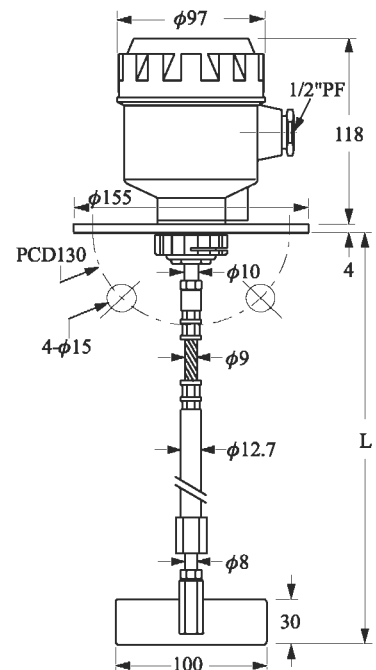

## SE130A/B/C SHAFT LENGTH ADJUSTABLE TYPE

- Vertical mounting
- Temp. (-10°C ~ 70°C)
- Standard Length (option):  
L-- 450 ~650mm (2.5 kg)  
L-- 650 ~1000mm (2.8 kg)  
L-- 750 ~1200mm (3.0 kg)
- Special length is made by order

# STANDARD SPECIFICATION

- Power source : A-110VAC, B-220VAC, C-240VAC, 50/60Hz
- Power consumption : 3W
- Contact capacity : SPDT, 5A/250VAC
- Rotary speed : 1 R.P.M.
- Insulation test voltage : AC 1500V × 1minute

- Torque : 0.5 ~1.0 kg-cm
- Connect : 1"PF screw or JIS 2-1/2" × 5kg/cm<sup>2</sup> flange
- Protection/ material : IP65 / ADC-12
- Conduit : 1/2"PF
- Specific gravity : 0.5g/cm<sup>3</sup> (30Lb/ft<sup>3</sup>)

## SE140A/B/C

### HI-TEMP TYPE

- Horizontal mounting
- Temp. (-10°C ~ 200°C)
- Weight: 2.1 kg

SE140A/B/C

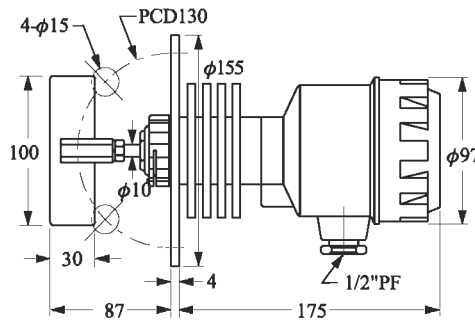

## SE141A/B/C

### HI-TEMP SHAFT PROTECTIVE TUBE TYPE

- Horizontal /Vertical mounting
- Temp. (-10°C ~ 200°C)
- The whole section from flange to paddle are made of SUS 304
- Standard Length (option):
  - L--250mm (2.6 kg)
  - L--500mm (2.9 kg)
  - L--750mm (3.2 kg)
- Special length is made by order

SE141A/B/C

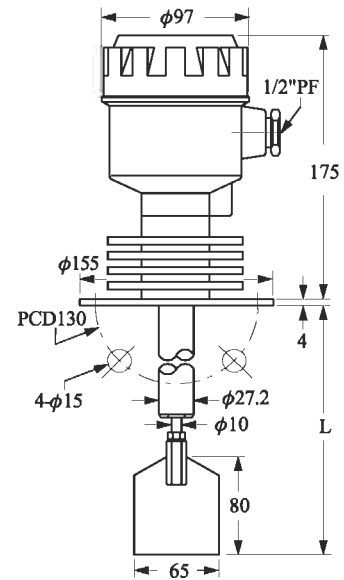

## SE146A/B/C

### HI-TEMP SHAFT LENGTH ADJUSTABLE TYPE

- Vertical mounting
- Temp. (-10°C ~ 200°C)
- Standard Length (option):
  - L-- 450 ~650mm (3 kg)
  - L-- 650 ~1000mm (3.3 kg)
  - L-- 750 ~1200mm (3.5 kg)
- Special length is made by order

SE146A/B/C

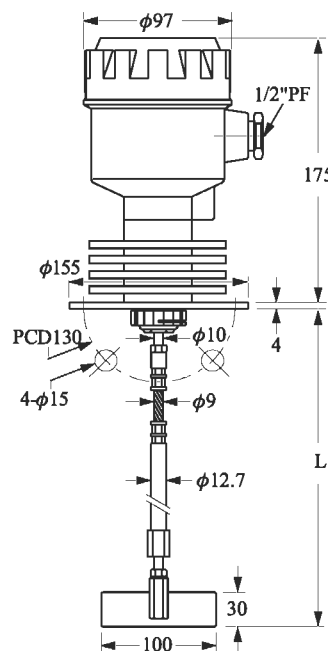

SE160A/B/C

## SE160A/B/C

### CABLE WIRE TYPE

- Vertical mounting
- Temp. (-10°C ~ 70°C)
- Standard Length (option):
  - L-- 450mm (2.5 kg)
  - L-- 650mm (2.8 kg)
  - L-- 750mm (3 kg)
- Special length is made by order

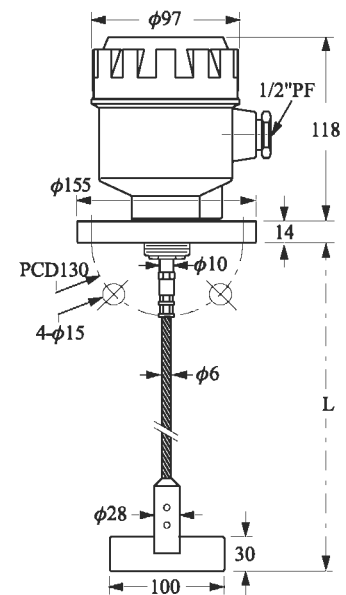

# STANDARD SPECIFICATION

- Power source : A-110VAC, B-220VAC, C-240VAC, 50/60Hz
- Power consumption : 3W
- Contact capacity : SPDT, 3A/250VAC
- Rotary speed : 1 R.P.M.
- Insulation test voltage : AC 1500V × 1 minute
- Torque : 0.5 ~ 1.0 kg-cm
- Connect : 1"PF screw or flange 1"~6"  
2-1/2" × 5kg/cm<sup>2</sup> (std.)
- Enclosure material : AL Alloy, ADC-12
- Enclosure Protection : Ex d IIB T4~T6
- Conduit : 1/2" (std.) or 3/4"NPT
- Specific gravity : 0.5g/cm<sup>3</sup> (30Lb/ft<sup>3</sup>)

## SE170A/B/C EXPLOSION PROOF SCREW TYPE

- Horizontal mounting
- Temp. (-10°C ~ 70°C)

SE170A/B/C

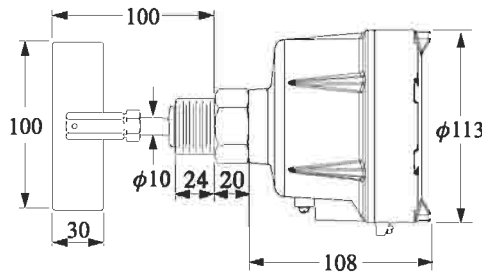

SE171A/B/C

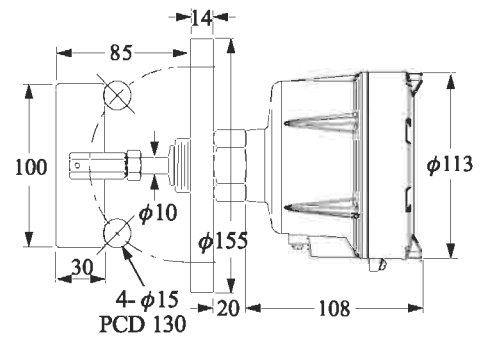

## SE171A/B/C EXPLOSION PROOF FLANGE TYPE

- Horizontal mounting
- Temp. (-10°C ~ 70°C)

## SE172A/B/C EXPLOSION PROOF SHAFT PROTECTIVE TUBE TYPE

- Horizontal /Vertical mounting
- Temp. (-10°C ~ 70°C)
- Standard Length (option):  
L-- 250mm  
L-- 500mm  
L-- 750mm
- Special length is made by order

SE172A/B/C

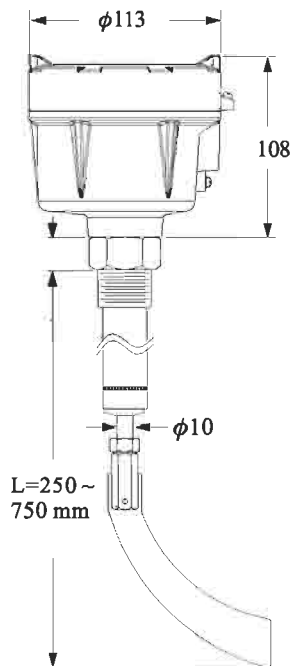

SE173A/B/C

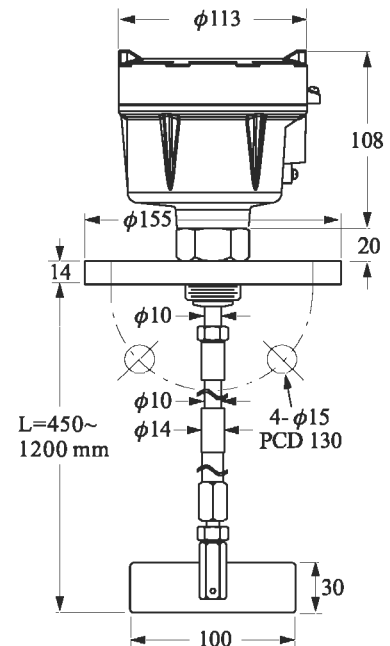

## SE173A/B/C EXPLOSION PROOF SHAFT LENGTH ADJUSTABLE TYPE

- Vertical mounting
- Temp. (-10°C ~ 70°C)
- Standard Length (option):  
L-- 450 ~ 650mm  
L-- 650 ~ 1000mm  
L-- 750 ~ 1200mm
- Special length is made by order

# STANDARD SPECIFICATION

- Power source : A-110VAC, B-220VAC, C-240VAC, 50/60Hz
- Power consumption : 3W
- Contact capacity : SPDT, 3A/250VAC
- Rotary speed : 1 R.P.M.
- Insulation test voltage : AC 1500V x 1minute
- Torque : 0.5 ~1.0 kg-cm

- Connect : 1"PF screw or flange 1"~6"  
2-1/2" x 5kg/cm<sup>2</sup> (std.)
- Enclosure material : AL Alloy, ADC-12
- Enclosure Protection : Ex d IIB T4~T6
- Conduit : 1/2" (std.) or 3/4"NPT
- Specific gravity : 0.5g/cm<sup>3</sup> (30Lb/ft<sup>3</sup>)

## SE174A/B/C

### SE174A/B/C

#### EXPLOSION PROOF HI-TEMP TYPE

- Horizontal mounting
- Temp. (-10°C ~ 200°C)

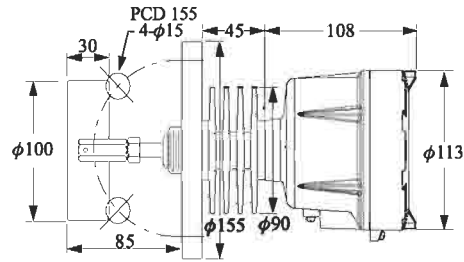

### SE175A/B/C

#### EXPLOSION PROOF HI-TEMP SHAFT PROTECTIVE TUBE TYPE

- Horizontal /Vertical mounting
- Temp. (-10°C ~ 200°C)
- Special length is made by order

### SE175A/B/C

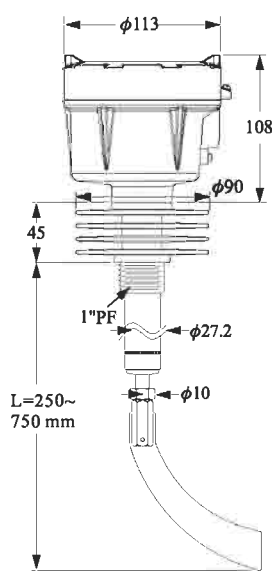

### SE176A/B/C

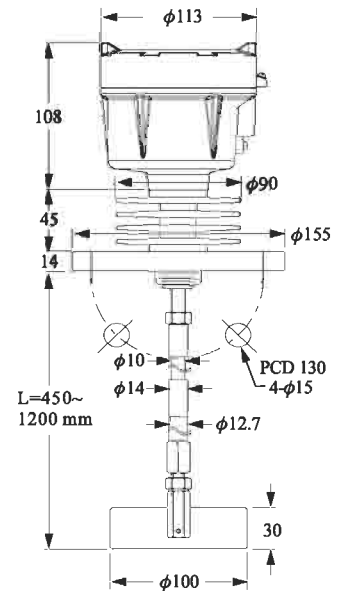

### SE176A/B/C

#### EXPLOSION PROOF HI-TEMP SHAFT LENGTH ADJUSTABLE TYPE

- Vertical mounting
- Temp. (-10°C ~ 200°C)
- Special length is made by order

## ■ Paddle Introduction (Big)

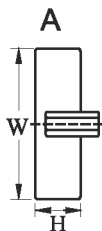

(A) 100x30 (WxH), Min. fixed hole diameter size φ90mm.

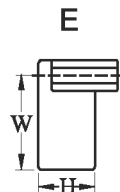

(E) 50x30 (WxH), Suitable for high S.G. raw material, application by small size paddle to decrease the material flowing impact directly.

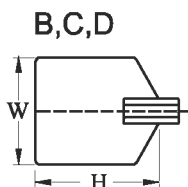

(B) 65x80 (WxH), Directly mounted into 2" fixed hole.  
(C) 65x120 (WxH), Directly mounted into 2" fixed hole.  
(D) 80x80 (WxH)

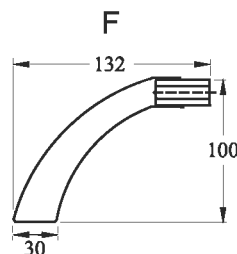

(F) Scimitar type paddle, Directly screwed through 1" diameter fixed hole, It is more easy to be mounted dispense with labor of tank cut-out.

# STANDARD SPECIFICATION

- Power source : A-110VAC, B-220VAC, C-240VAC, D-24VAC 50/60Hz
- Power consumption : 1.5W
- Contact capacity : AC 250V 3A
- Rotary speed : 1 R.P.M.
- Protection/ material : IP65 / PC
- Temp. : -10°C ~ 70°C
- Cable length : 30cm (available for custom length)
- Torque : 30 ~100 kg-cm
- Specific gravity : 0.3g/cm<sup>3</sup> (20Lb/ft<sup>3</sup>)

## SE180A/B/C/D CROSS-LIKE 4 BLADE PADDLE

- Horizontal mounting
- Weight : 0.42 kg

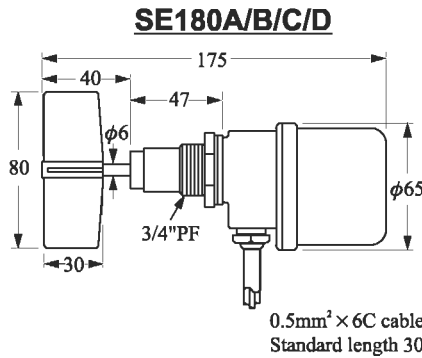

## SE180□CRI

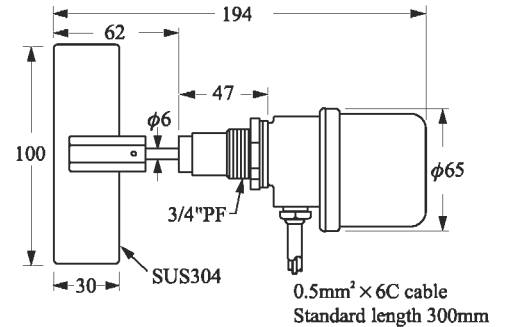

## SE180□CRH SCIMITAR TYPE PADDLE

- Horizontal mounting
- Weight : 0.42 kg

## SE180□CRH

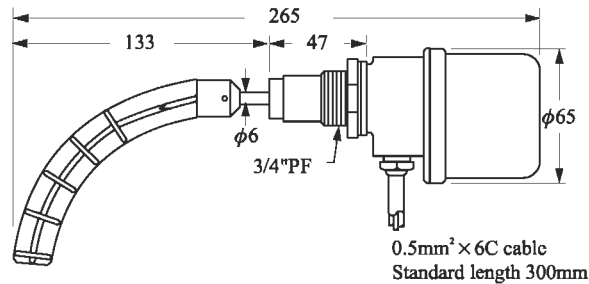

## SE180□CRI RECTANGLE 100 x 30 SUS304 PADDLE

- Horizontal mounting
- Weight : 0.48 kg

## SE184□CRI

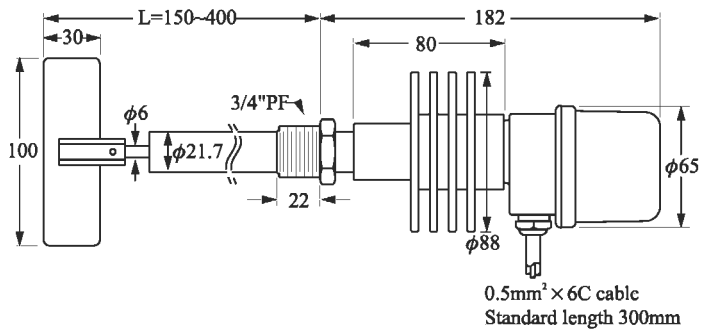

## SE184□CRI HI-TEMP TYPE SUS304 PADDLE

- Horizontal / Vertical mounting
- Temp. Max: 200°C

## ■ Paddle Introduction (Mini)

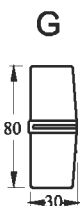

(G) Cross type paddle  
material: polycarbonate

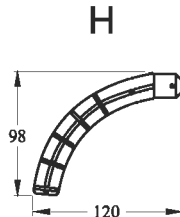

(H) Scimitar type paddle, directly  
screwed through 3/4" diameter  
fixed hole.

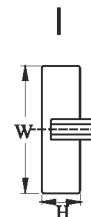

(I) 100x30 (WxH)  
Material: SUS304

# EXAMPLES OF MOUNTING

## EXAMPLES OF MOUNTING TO TANK

Where the SE110A type paddle cannot be attached to the main shaft from inside the storage tank. The paddle can be set on the main shaft when the distance from the flange face to the tip of paddle is more than 90mm, the relative dimensions being as illustrated right.

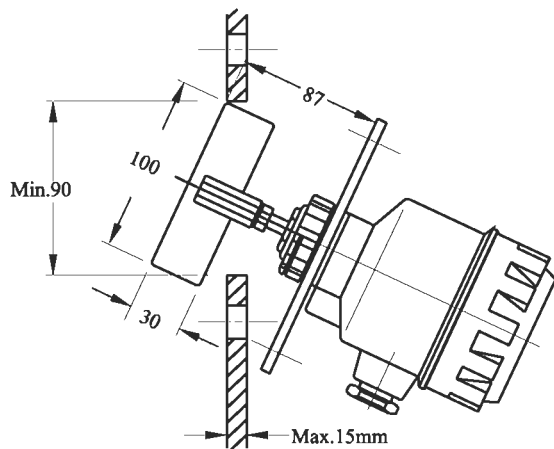

## EXAMPLES OF MOUNTING TO TANK

The scimitar paddle penetrate through 3/4"PF inlet directly like illustrated drawing, then screw tightly.

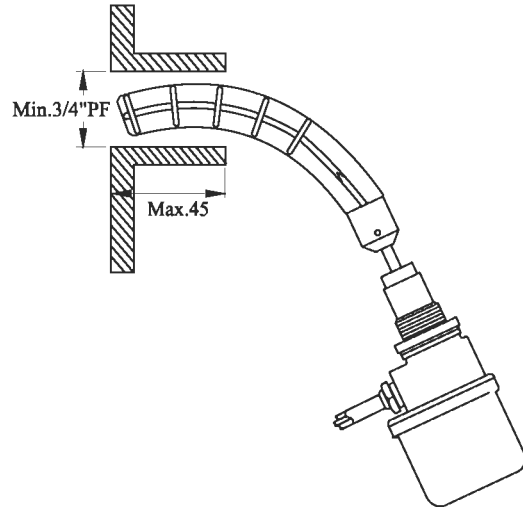

## EXAMPLES OF MOUNTING TO INJECTION MOLDING MACHINE

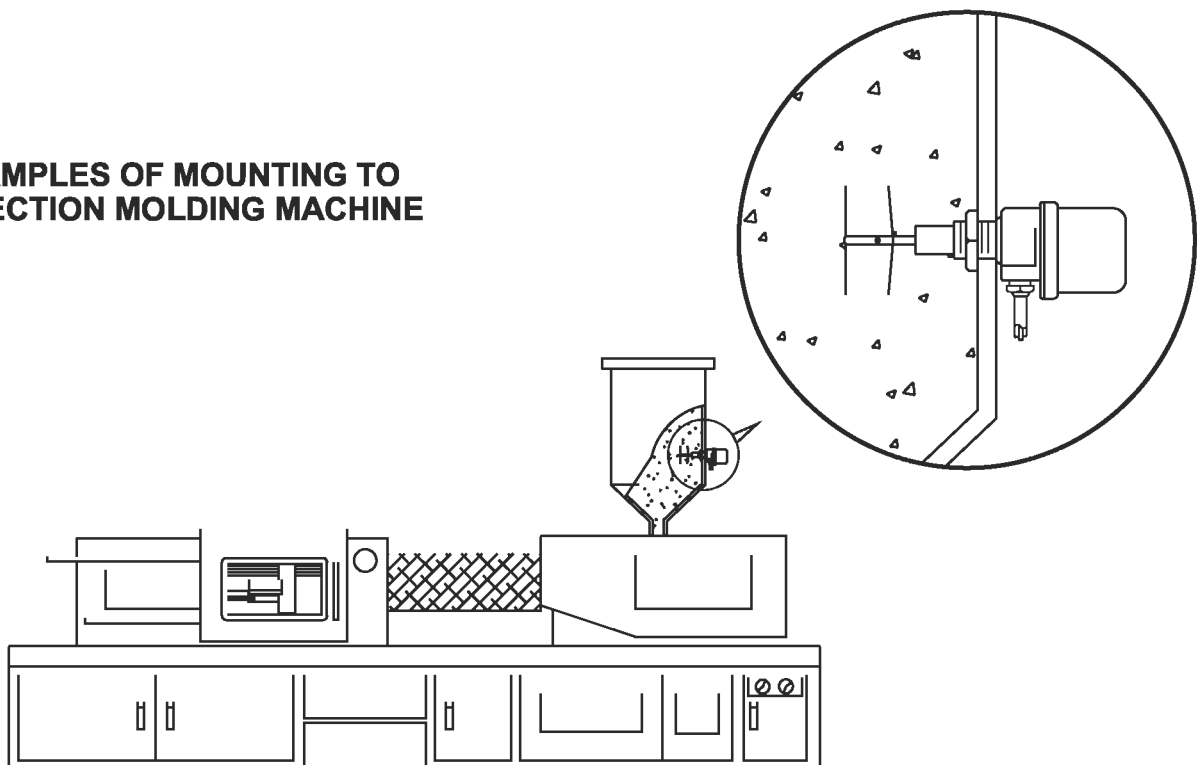



## EXAMPLE

---

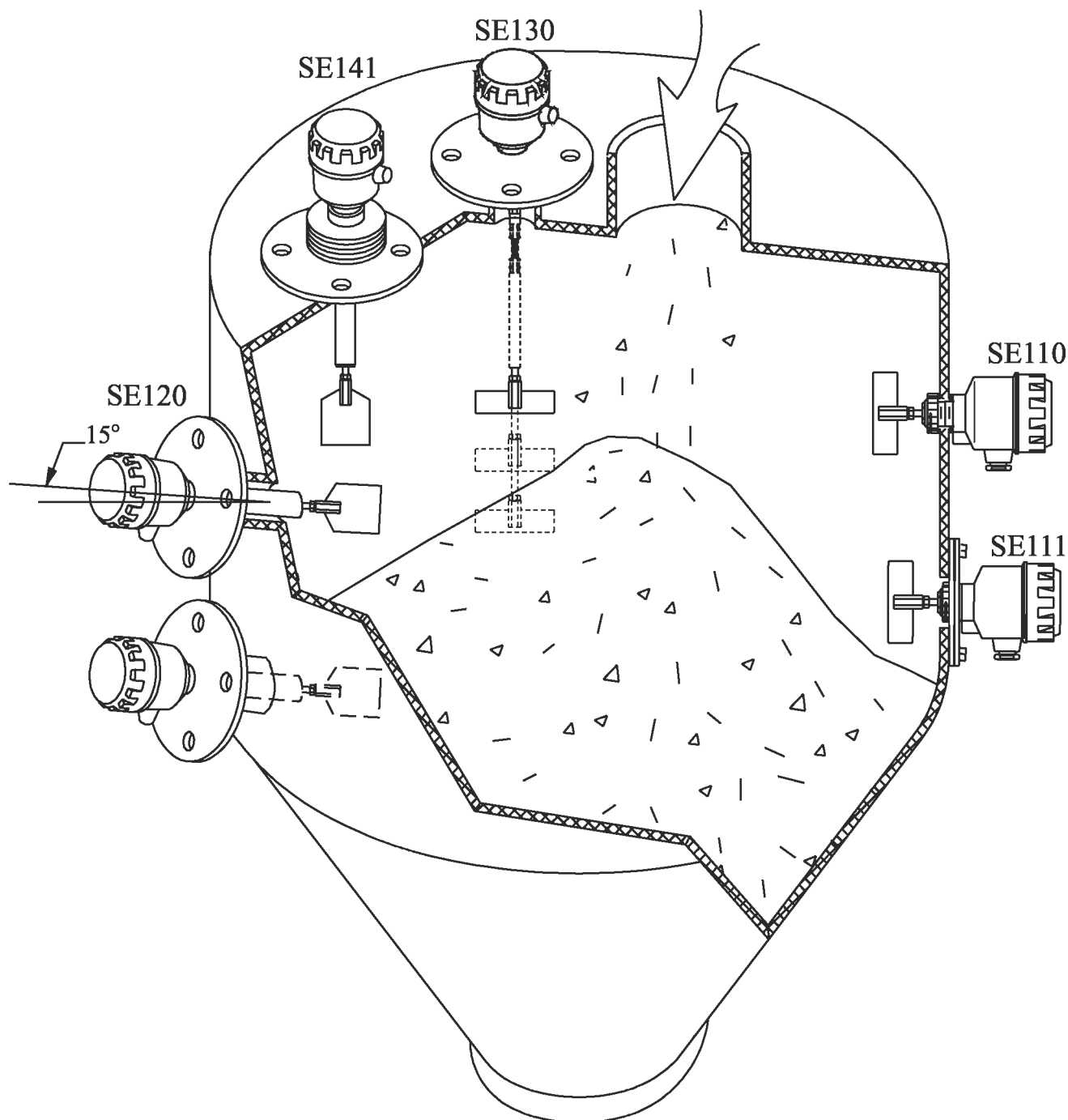

### INSTALLATION NOTICES

1. Please side mount the sensor by inclined  $15^{\circ}$ ~ $20^{\circ}$  to decrease the material inflowing impact.
2. Please select RP40 family items on tank internal operating temperature more than  $60^{\circ}\text{C}$ .
3. SE110~SE140 on 1" connection pipe inlet, please apply scimitar type to screw directly.
4. SE130, SE146 family items are with flexible and extensible shaft.

# ORDER INFORMATION

SE1

**Model** \_\_\_\_\_

- |                                   |                           |
|-----------------------------------|---------------------------|
| 10 : Standard type                | 60 : Cable wire type      |
| 20 : Shaft protective tube type   | 70 : Explosion Proof type |
| 30 : Shaft length adjustable type | 80 : Mini type            |
| 40 : Hi-temp type                 |                           |

**Voltage** \_\_\_\_\_

- A : 110V B : 220V C : 240VAC D : 24VAC 50/60HZ

**Mounting** \_\_\_\_\_

Size for flange or screw	
C: 3/4"	I: 4"
D: 1"	J: 5"
E: 1-1/2"	K: 6"
F: 2"	S: Others
G: 2-1/2"	3: 1-1/4"
H: 3"	

Pressure range or other
M: 5kg/cm <sup>2</sup>
N: 10kg/cm <sup>2</sup>
O: 150 Lbs
P: 300 Lbs
Q: PT
R: PF
T: BSP
S: Others

\* SE110~SE170 series:  
The size of connecting screw is 1".

**Paddle Shapes** \_\_\_\_\_

**SE110~SE170**

- A : 100x30 (WxH)
- B : 65x80 (WxH)
- C : 65x120 (WxH)
- D : 80x80 (WxH)
- E : 50x30 (WxH)
- F : Scimitar

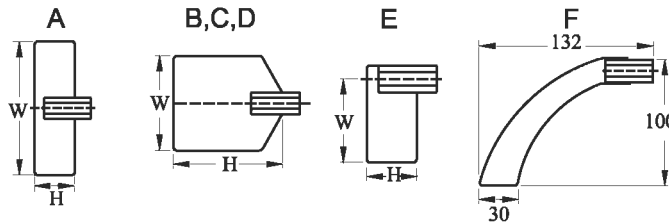

**SE180 (Mini paddle type)**

- G : Cross type paddle
- H : Scimitar type paddle
- I : 100x30 (WxH)

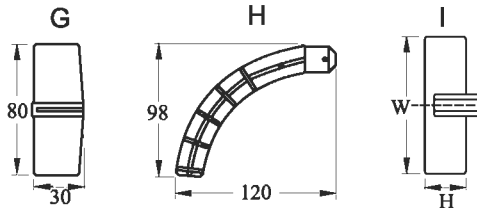

**Length (mm)** \_\_\_\_\_

SE110~170 L: The distance from flange to paddle.  
SE180 L: Length of cable.  
The total length of item will be allowed a tolerance to 6mm.

**\* Order Notice**

1. Please make sure the Voltage 24VAC, 110VAC, 220VAC or 240VAC, 50/60 Hz.
2. Please make sure the side or top mounting.
3. Please make sure the material specific gravity (S.G.) value.
4. Please make sure whether any bridge block or vibrating motor installed onto the tank wall.  
Please try to apply our item SA140 capacity sensor.
5. Please make sure the rotary paddle size is available to enter into the flange inlet.