

Signal Conditioner

SB Series

Slim, Economical, Compact

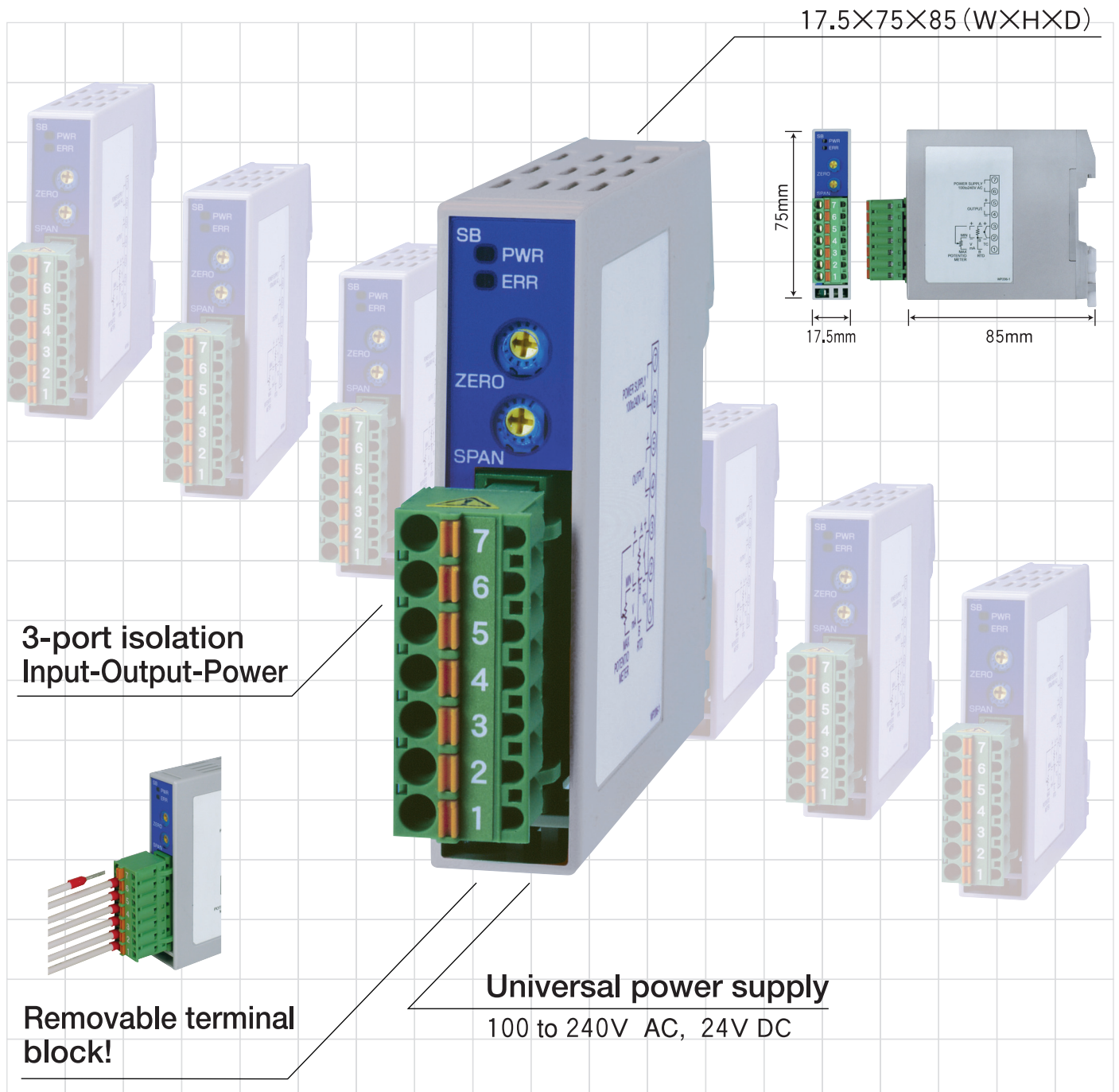

COST or cost

Choose your cost.

“Cost reduction” is a key phrase for successful business.

The SB series is designed to meet the needs of the standard users and the cost focused.

When you need a reliable, standard conditioner, the SB series can help.

Safety standard: UL/C-UL, CE marking pending

Features

■ Removable terminal block

Front access makes wiring and maintenance easy.

■ Space-saving

17.5 x 75 x 85mm (W x H x D)

■ 3-port isolation

Input — Output — Power at 500V DC

■ Universal power supply

24V DC (20 to 28V DC) or
100 to 240V AC (85 to 264V AC)



Models

Model	Input type
SBE	Thermocouple
SBR	RTD
SBA	DC current
SBV	DC voltage
SBP	Potentiometer
SBD	Current loop supply

Ordering example: Please select and insert specifications from the table “Model range and codes” on the next page.
(For SBE and SBR, Please specify an input range.)

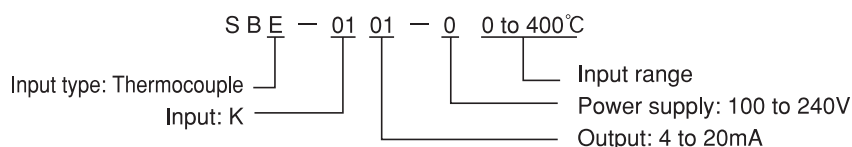

Model range and codes

S B <input type="checkbox"/> - <input type="checkbox"/> <input type="checkbox"/> - <input type="checkbox"/>		Series name: SB series [17.5 x 75 x 85mm (W x H x D)]
Input type	E	Thermocouple
	R	RTD
	A	DC current
	V	DC voltage
	P	Potentiometer
	D	Current loop supply
Input	SBE 01: K, 02: J, 03: R, 04: S, 05: B, 06: E, 07: T, 08: N, 09: PL-II, 10: W5Re/W26Re, 11: W3Re/W25Re	
	SBR 01: Pt100, 02: JPt100, 03: Pt1000, 04: Cu50, 05: Cu100	
	SBA 01: 4 to 20mA DC, 02: 0 to 20mA DC, 03: 2 to 10mA DC, 04: 0 to 10mA DC	
	SBV 01: 0 to 100mV DC, 02: 0 to 1V DC, 03: 0 to 5V DC, 04: 1 to 5V DC, 05: 0 to 10V DC	
	SBP 01: 100Ω to 10kΩ	
Output	SBD 01: 4 to 20mA DC(built-in shunt resistor 50Ω)	
	01: 4 to 20mA DC, 02: 0 to 20mA DC, 03: 0 to 12mA DC, 04: 0 to 10mA DC, 05: 0 to 1V DC, 06: 0 to 5V DC, 07: 1 to 5V DC, 08: 0 to 10V DC	
Power supply	0	100 to 240V AC
	1	24V DC

General specifications

External dimensions	17.5 x 75 x 85mm (W x H x D)
Mounting	DIN rail mounting
Case	Flame-resistant resin Color, Light gray
Panel	Polycarbonate
Display	PWR indicator (Green) : Lights when power-on. Flashes in 0.5 second cycles when an error has occurred in non-volatile IC memory. ERR indicator (Red) : Flashes in 0.25 second cycles when input is 110% or more. Flashes in 0.5 second cycles when input is -10% or less.
Basic accuracy	Thermocouple : Within $\pm 0.2\%$ of input span or within $\pm 2^\circ\text{C}$ (4°F) Whichever is greater. R, S input, less than 200°C (400°F) : Within $\pm 6^\circ\text{C}$ (12°F) B input, less than 300°C (600°F) : Accuracy is not guaranteed. K, J, E, T, N input, less than 0°C (32°F) : Within 4°C (8°F) RTD : Within $\pm 1.5^\circ\text{C}$ (3°F) DC current : Within $\pm 0.2\%$ DC voltage : Within $\pm 0.2\%$ Potentiometer : Within $\pm 0.2\%$ Current loop supply : Within $\pm 0.2\%$
Cold junction compensation accuracy	Within $\pm 1^\circ\text{C}$ at -5 to 55°C (SBE only)
Response time	1sec (typical) (0 \rightarrow 90%)
Temperature coefficient	$\pm 0.015\%/^\circ\text{C}$
Insulation resistance	Between Input — Output — Power: 10MΩ or more, at 500VDC
Dielectric strength	Between Input — Output — Power: 2000V AC for 1 minute
Power supply	100 to 240V AC(85 to 264V AC) 50/60Hz, 24V DC(20 to 28V DC)
Ambient temperature	-5 to 55°C
Ambient humidity	35 to 85%RH(non-condensing)
Weight	Approx. 80g

Input specifications

Thermocouple	Input range	
K	-200 to 1370°C	-328 to 2498°F
J	-200 to 1000°C	-328 to 1832°F
R	-50 to 1760°C	-58 to 3200°F
S	-50 to 1760°C	-58 to 3200°F
B	0 to 1820°C	32 to 3308°F
E	-200 to 800°C	-328 to 1472°F
T	-200 to 400°C	-328 to 752°F
N	-200 to 1300°C	-328 to 2372°F
PL-II	0 to 1390°C	32 to 2534°F
W5Re/W26Re	0 to 2315°C	32 to 4199°F
W3Re/W25Re	0 to 2315°C	32 to 4199°F

RTD	Input range	
Pt100	-200 to 850°C	-328 to 1562°F
JPt100	-200 to 500°C	-328 to 932°F
Pt1000	-200 to 850°C	-328 to 1562°F
Cu50	-50 to 150°C	-58 to 302°F
Cu100	-50 to 150°C	-58 to 302°F

DC current	Shunt resistor (built-in)
0 to 10mA DC	100Ω
2 to 10mA DC	
0 to 20mA DC	50Ω
4 to 20mA DC	

DC voltage	Input resistance
0 to 100mV DC	1MΩ
0 to 1V DC	
0 to 5V DC	100kΩ
1 to 5V DC	
0 to 10V DC	

Potentiometer	
Whole resistance	100Ω to 10kΩ

Current loop supply	Shunt resistor (built-in)
4 to 20mA DC	50Ω

Output specifications

DC current

Output	Allowable load resistance	Zero adjustment range	Span adjustment range
4 to 20mA DC	600Ω or less	-2.5 to 2.5%	97.5 to 102.5%
0 to 20mA DC	600Ω or less	0 to 2.5%	97.5 to 102.5%
0 to 12mA DC	1kΩ or less	0 to 2.5%	97.5 to 102.5%
0 to 10mA DC	1kΩ or less	0 to 2.5%	97.5 to 102.5%

DC voltage

Output	Allowable load resistance	Zero adjustment range	Span adjustment range
0 to 1V DC	100Ω or more	0 to 2.5%	97.5 to 102.5%
0 to 5V DC	500Ω or more	0 to 2.5%	97.5 to 102.5%
1 to 5V DC	500Ω or more	-2.5 to 2.5%	97.5 to 102.5%
0 to 10V DC	1kΩ or more	0 to 2.5%	97.5 to 102.5%

Terminal arrangement

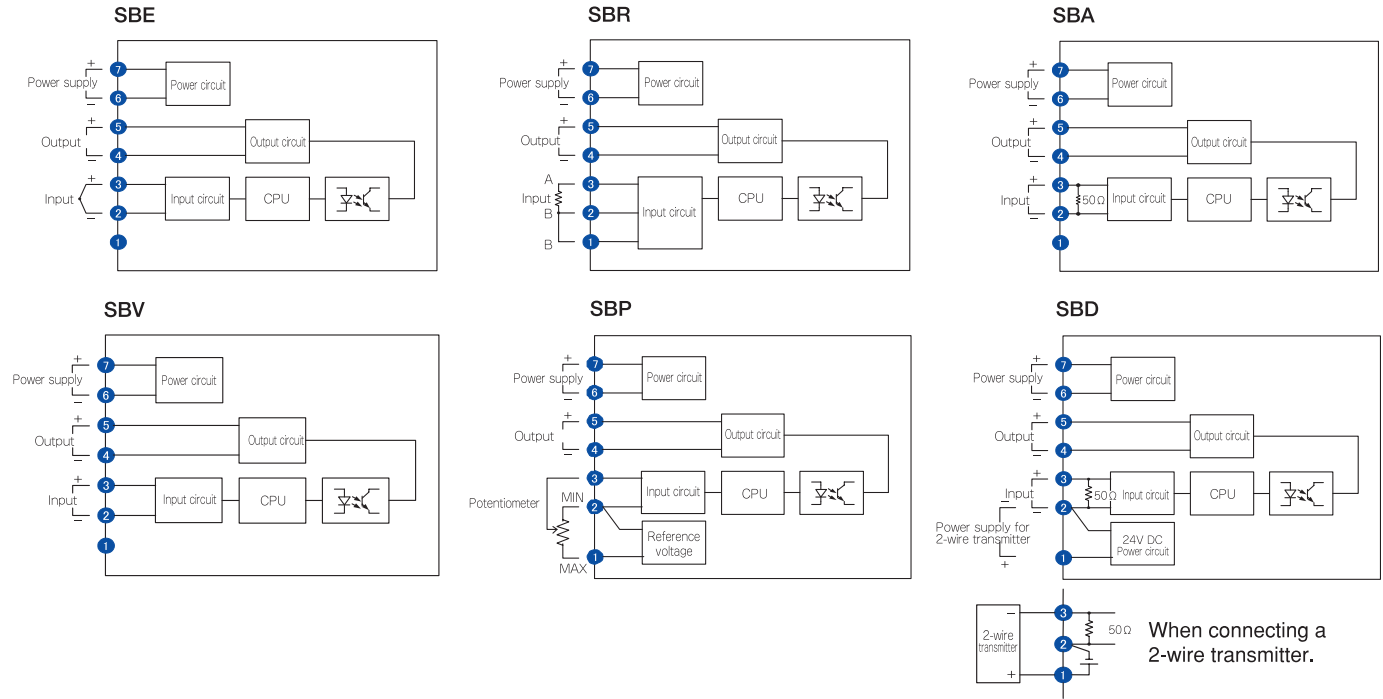

External dimensions (Unit: mm)

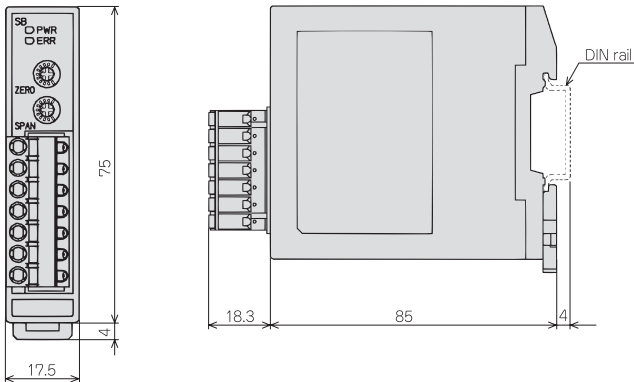

Recommended ferrules

Ferrules with insulation sleeve	Conductor cross sections	Crimping pliers
Al 0.25-6 BU	0.2~0.25mm ²	CRIMPFOX ZA 3 CRIMPFOX UD 6
Al 0.34-8 TQ	0.25~0.34mm ²	
Al 0.5-8 WH	0.34~0.5mm ²	
Al 0.75-8 GY	0.5~0.75mm ²	
Al 1.0-8 RD	0.75~1.0mm ²	
Al 1.5-8 BK	1.0~1.5mm ²	
Al 2.5-8 BU	1.5~2.5mm ²	

Please use ferrules made by Phoenix Contact GMBH & CO.

DIN rail mounting

SB series

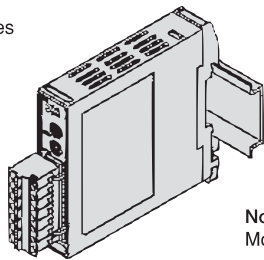

Hook the unit into the upper part of the DIN rail for mounting.

DIN rail

Note:
Mount the unit vertically.

Recommended end plates (for DIN rail)

Model
Shinko end plate AEP-001-1 (sold separately)

- To ensure safe and correct use, thoroughly read and understand the manual before using this instrument.
- This instrument is intended to be used for industrial machinery, machine tools and measuring equipment. Verify correct usage after consulting purpose of use with our agency or main office. (Never use this instrument for medical purposes with which human lives are involved.)
- External protection devices such as protection equipment against excessive temperature rise, etc. must be installed, as malfunction of this product could result in serious damage to the system or injury to personnel. Also proper periodic maintenance is required.
- This instrument must be used under the conditions and environment described in the manual. Shinko Technos Co., Ltd. does not accept liability for any injury, loss of life or damage occurring due to the instrument being used under conditions not otherwise stated in the manual.

Caution with respect to Export Trade Control Ordinance

To avoid this instrument from being used as a component in, or as being utilized in the manufacture of weapons of mass destruction (i.e. military applications, military equipment, etc.), please investigate the end users and the final use of this instrument. In the case of resale, ensure that this instrument is not illegally exported.



This catalog is as of December 2005, and its contents are subject to change without notice. If you have any inquiries, please consult us or our agency.

Manufacturer

SHINKO TECHNOS CO., LTD. OVERSEAS DIVISION

Reg. Office : 2-5-1, Senbahigashi, Minoo, Osaka, 562-0035, Japan
 Tel : 81 - 72 - 727 - 6100
 Fax : 81 - 72 - 727 - 7006
 URL : <http://www.shinko-technos.co.jp>
 E-mail : overseas@shinko-technos.co.jp