

Hand-held Digital Infrared Radiation Thermometer

IRT-100, IRT-200, IRT-300



Measure the temperature of an object without touching it with our palm-sized IRT-100.
 IRT-200: A small, light radiation thermometer equipped with bright finder
 IRT-300: Measure a wide range of temperatures from -50°C to 3000°C.

Standard specifications

Model name	IRT-100-TF	IRT-100-TA
Measuring system	Infrared radiation thermometer	
Detecting element	Thermopile	
Measuring range	-30 to 350°C	-40 to 500°C
Accuracy ratings	Within $\pm 1\%$ of measured value or $\pm 2^\circ\text{C}$ whichever is greater However, -30 to 0°C: Within $\pm 3^\circ\text{C}$	Within $\pm 1\%$ of measured value or $\pm 2^\circ\text{C}$ whichever is greater However, -30 to 0°C: Within $\pm 3^\circ\text{C}$ lower than -30°C: Within $\pm 5^\circ\text{C}$
Repeatability	Within $\pm 1^\circ\text{C}$	
Response time	0.8s (90% response)	
Collimation		Laser beam marks the center of the area measured.
Beam diameter		Approx. 5mm (at a distance of 1m)
Beam output		1mW or less (670nm), JIS class 2
Display system	LCD 3 digits indication	
Resolution	-19.9 to 99.9°C: 0.1°C, Higher than 100°C or lower than -20°C: 1°C	
Indication update cycle	Approx. 0.25s	
Indication contents	Current reading, Maximum reading, Minimum reading, Reading hold, Emissivity, Low battery	Current reading, Maximum reading, Minimum reading, Reading hold, Emissivity, Alarm value, Low battery
Auto-Power-Off	Power is turned off after Approx. 30 seconds	
Alarm		High limit alarm (Buzzer) Low limit alarm: Option
Emissivity compensation	DARK : 0.95 BRIGHT : 0.80 STD : 1.00	DARK : 0.95 BRIGHT : 0.80 FREE : 0.30 to 1.90 (Initial value 1.00/0.01step)
Operating temperature	0 to 50°C	
Operating humidity	90%RH or less (No condensation)	
Storage temperature	-20 to 55°C	
Power supply	Alkaline size AA battery (2 pieces)	
Battery power	Continuous measurement: Approx. 70 hours	Continuous measurement: Approx. 50 hours
Weight	Approx. 160g	Approx. 180g

External dimension

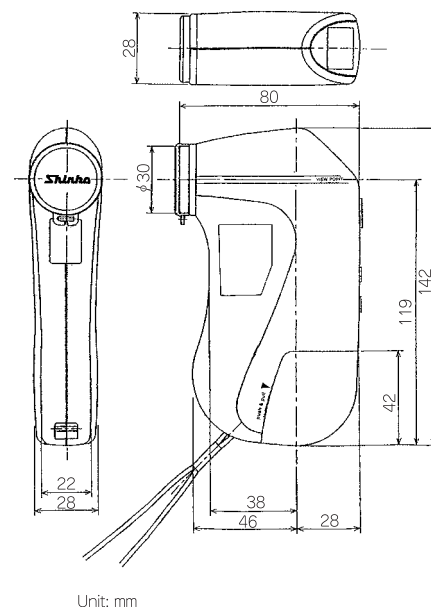

Unit: mm

The relation of Measuring distance and Measuring diameter

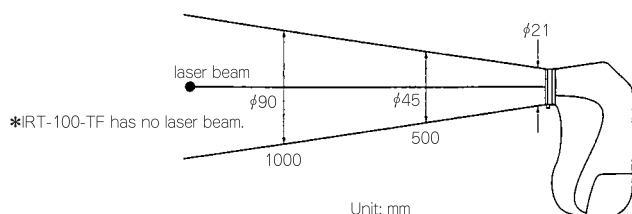

Unit: mm

Shinko

Standard specifications

Model name	IRT-200-HS
Measuring system	Narrow band radiation thermometer
Detecting element	Si
Measuring wavelength	0.9 μm
Measuring range	600 to 2000°C
Accuracy ratings	Lower than 1000°C : Within ±6°C 1000 to 1500°C : Within ±0.6% of measured value Higher than 1500°C : Within ±1.2% of measured value
Repeatability	Within ±1°C
Resolution	1°C
Response time	0.2s (95% response)
Emissivity compensation	0.100 to 1.900
Operations	Maximum value, Minimum value, Average value
Signal modulation	Peak, Delay
Display system	LCD digital 4 digits, Displayed in the finder and on the panel board
Data memory function	Max. 500 pieces of data
Communication function	RS-232C
Collimation	Direct viewing finder
Lens diameter	φ20mm
Thermocouple input	K thermocouple: -50 to 800°C, Accuracy rating: ±2°C (23°C ±5°C)
Other functions	Auto-Power-Off, Automatic back-lit display, Continuous measurement, °C/°F selection, Battery check, High/Low limit alarms
Operating temperature	0 to 50°C
Power supply	Alkaline size AA battery (2 pieces) (Continuous measurement: Approx. 20 hours)
Weight	Approx. 350g

External dimension

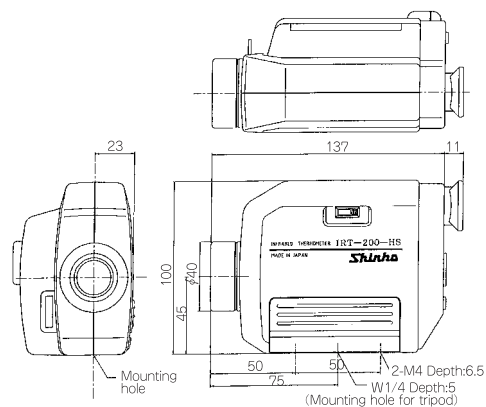

Unit: mm

The relation of Measuring distance and Measuring diameter

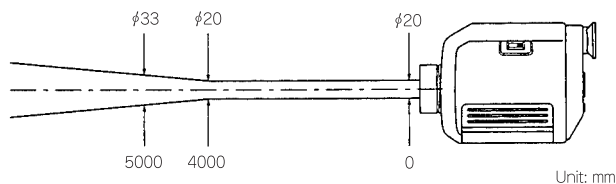

Standard specifications

	IRT-300-AT	IRT-300-AS
Model name	IRT-300-AT	IRT-300-AS
Measuring system	Wide band radiation thermometer	Narrow band radiation thermometer
Detecting element	Thermopile	Si
Measuring wavelength	8 to 13 μm	0.96 μm
Measuring range	-50 to 1000°C	600 to 3000°C
Accuracy ratings	Lower than 200°C: Within ±2°C ±1digit Higher than 200°C: Within ±1% ±1digit of measured value	Lower than 1500°C: Within ±0.5% of measured value ±1digit 1500 to 2000°C: Within ±1% of measured value ±1digit Higher than 2000°C: Within ±2% of measured value ±1digit
Repeatability	1°C ±1digit	
Resolution	1°C (Higher than 50°C)	1°C
Response time	1s	0.5s
Distance factor	40	100
Measuring distance	0.7m to ∞	0.5m to ∞
Collimation	Direct viewing finder	
Display system	LCD digital 4 digits, Displayed in the finder and on the panel board	
Emissivity compensation	ε = 1.00 to 0.10 (0.01 step)	
Signal modulation	Modulation: Real, Peak, Delay, Valley Modulation ratio: 0 to 99 seconds (1-sec step) Peak hold, Valley hold, Hold with the measuring switch turned off	
Output signal	Digital transmission (RS-232C)	
Other functions	Auto-Power-Off, Continuous measurement, °C/°F selection, Battery check, High/Low limit alarms	
Operating temperature	0 to 50°C	
Power supply	Alkaline size AA battery (4 pieces) (Continuous measurement: Approx. 20 hours)	
Weight	Approx. 700g	

External dimension

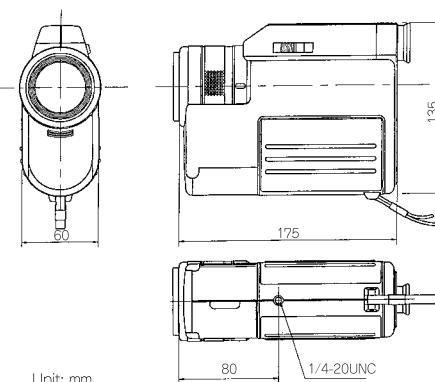

Unit: mm

- This catalog is as of August, 2003, specifications are subject to change for improvement without prior notice.
- When inquiring, please consult our agency or the shop where you purchased the unit.



SHINKO TECHNOS CO., LTD. OVERSEAS DIVISION

Reg. Office : 1-2-48, Ina, Minoo, Osaka, 562-0015, Japan
 Mail Address: P. O. Box 17, Minoo, Osaka, Japan
 Tel : 81 - 72 - 721 - 2781
 Fax : 81 - 72 - 724 - 1760
 URL : <http://www.shinko-technos.co.jp>
 E-mail : overseas@shinko-technos.co.jp