

PROCESS CONTROLLER



ISO9001 Certified
J Q A - 2 0 5 5

REMARKABLE !



HCD-100 SERIES

Shinko

PROCESS CONTROLLER HCD-100

meets the various needs featuring the accuracy $\pm 0.1\%$ and the sampling period 0.1sec.

■ Features

Accuracy $\pm 0.1\%$

To satisfy the requirements on strict accuracy, $\pm 0.1\%$ of accuracy is achieved.

Input sampling period 0.1 sec.

Quickly reacts to an instant change. Thus it can cope with the process such as pressure or flow.

Interactive mode multi-display

Interactive system key operation by multi-display 16-digit \times 2 lines.

Cascade control

One HCD-100 allows the cascade control.

Memory card for easy operation

SAVE or LOAD of the setting values is performed using memory-card.

Various attached functions and optional functions are provided to meet your all sorts of needs.



■ LCD display examples

- Main setting value setting

```
*Select Group*  
(MAIN SET)
```

- Setting value memory number selection

```
*Select Group*  
(MEMORY)
```

- Main setting value setting

```
*MAIN SET*  
SV= 1370.0° C
```

- PID parameter setting

```
*Select Group*  
(PID PARAMETERS)
```

- Main output parameter setting

```
*Select Group*  
(OUTPUT PARAMS)
```

- Main setting parameter setting

```
*Select Group*  
(MAIN SET PARAMS)
```

- Input parameter setting

```
*Select Group*  
(INPUT PARAMS)
```

- Other function selection

```
*Select Group*  
(Other FUNCTION)
```

- Main output manipulating value display [Bar-graph]

```
MV(main) 100.0%  
[■■■■■■■■■■]
```

Names and functions of each part

① Process variable display

Displays the process variable.

② Setting value display

Displays the setting value.

③ Setting value memory number display

Displays the setting value memory number.

C1 Main output indicator

Lights when main output ON.

C2 Sub-output indicator

Lights when sub-output ON.

④ Action status indicators

REM: Lights when controlling by remote.

MAN: Lights when operating by manual.

AUTO: Lights when controlling automatically.

AT: Blinks when auto-tuning is performing.

⑤ Multidisplay

When setting, displays the setting contents. When running, displays the manipulating value.

SB Sensor burnout indicator

Lights when sensor burnout.

A1 Alarm 1 indicator

Lights when alarm action output 1 ON.

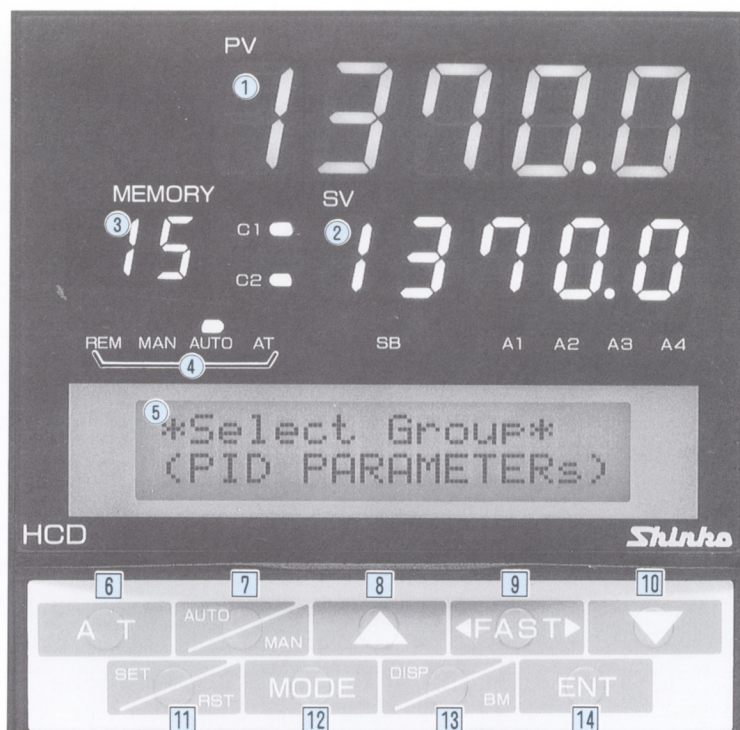

A2 Alarm 2 indicator

Lights when alarm action output 2 ON.

A3 Alarm 3 indicator

Lights when alarm action output 3 ON.

A4 Alarm 4 indicator

Lights when alarm action output 4 ON.

⑥ Auto-tuning key

Starts or cancels the auto-tuning function.

⑦ Auto/Manual key

Changes the operation, automatic or manual.

⑧ Increase key

Increases the numerical value.

⑨ Fast key

Makes the setting value to change faster.

⑩ Decrease key

Decreases the numerical value.

⑪ Set/Reset key

Changes the mode, setting or monitoring.

⑫ Mode key

Selects the setting mode.

⑬ Output display changing key

Switches the indication on multidisplay or turns back the setting mode.

⑭ Entry key

Enters the numerical value.

Attached functions

Multi-range function	Kind of input can be selected with key operations.
Scaling function	Thermocouple, RTD input: Applicable to each range. Voltage, Current input: Applicable to the range -1999.9 to 2000.0 at will. Decimal point is settable freely.
PV filter function	Reduces the input fluctuation due to noise by digital filter.
Sensor correcting function	In case sensor mounting location differs from controlling place, corrects the difference shifting the input value.
Setting value ramp function	When changing the main setting value, it changes the setting value with specified changing rate.
Control output direct and reverse change	Changes the control mode between Direct action (cooling) and Reverse action (heating).
AT bias function	Bias value can be set so as not to exceed the PV than SV when the autotuning is performing.
Setting value lock function	It protects the setting values from careless change. However, it cannot be used if the option "SE" security function is applied.
Balanceless bumpless function	Prevents the manipulating value from sudden change when changing the operation between manual and automatic. AUTO→MANUAL: Makes the manipulating value (MV) when controlling automatically to the MV when operating by manual. MANUAL→AUTO: Operates so that MV when operating by manual can be the initial value of the MV when controlling automatically.
Extraction of the square root operating function	To correspond to the use of flow detection by differential pressure, it operates the extraction of the square root.
Low level cut off function	With square root extraction nearly 0 level, the result changes largely correspond to a small input change, therefore, the value less than the value set in advance is made to 0 to prevent from the influence.
Setting value memory function	It memorizes 14 kinds of setting values (Main setting, PID and ARW, Alarm setting, Dead band, P offset, Sub-proportional band and Sub-derivative time) in 15 files. They are easily called by key operation.
Power failure countermeasure	When power failure time exceeds 30ms, the setting data are backed up with lithium battery.
Self-diagnostic function	Watches the CPU by watchdog timer, and when abnormal status has occurred, makes the instrument to initial status making all output OFF.
Automatic cold junction temperature compensation	When using thermocouple input, it detects the temperature at the connecting terminals between thermocouple and instrument, and always makes it the same status at which the reference junction located at 0°C.
Burnout	In case of thermocouple or RTD input, when the sensor burns out, it makes the control output off and (----) blinks on PV display.

■ Standard specifications

Input	Thermocouple	K, J, R, S, PL-II, B, E, T, W/Re 5-26 and N (JIS, IEC) Signal source resistance effect : 0.5 μ V/ Ω Input impedance: 1M Ω or more When input burnout: Upscale (or Downscale)	
	RTD	Pt 100, 3-wire system (JIS, IEC) Allowable input lead wire resistance: per wire 5 Ω or less When input burnout : Upscale	
	DC current	0 to 20mA, 4 to 20mA, impedance: 250 Ω When input burnout: Downscale	
	DC voltage	-10 to 10mV, 0 to 10mV, 0 to 100mV, 0 to 1V, 0 to 10V, -1 to 1V and 1 to 5V. Allowable input voltage: 15V or less Input impedance: 1M Ω	
Display	Process variable	7-segment Red LED display 5-digit, size 14.3(H) \times 8(W)mm	
	Setting value	7-segment Green LED display 5-digit, size 10(H) \times 5(W)mm	
	Setting value memory number	7-segment Green LED display 2-digit, size 8(H) \times 4(W)mm	
	Multidisplay	16-digit \times 2-line LCD display, with LED backlight (the contrast is adjustable)	
Accuracy	Indication and Setting	Within \pm 0.1% of rated scale However, TC input T : -270 to -200 $^{\circ}$ C, Within \pm 5 $^{\circ}$ C \pm 1 digit TC input B : 0 to 300 $^{\circ}$ C, Accuracy is not guaranteed	
	Cold junction compensation	\pm 0.5 $^{\circ}$ C, at ambient temperature 25 $^{\circ}$ C \pm 1 $^{\circ}$ C	
Control action	PID action	With Auto-tuning function Proportional band: 0.1 to 999.9% (ON/OFF action if set to 0.0) Integral time : 1 to 9999sec. (off when set to 0) Derivative time : 1 to 9999sec. (off when set to 0)	
	ARW	0 to 100% (Functions as overshoot preventive factor when acting PID action.)	
	Proportional cycle	1 to 120sec. [not available for the type (-A/ \square)] Factory adjusted as 3sec. (-S/ \square), 30sec. (-R/ \square)	
	Output limiter	0 to 100.0% [-5.0 to 105.0% for current output (-A/ \square)]	
	Output changing rate limiter	0 to 100.0%/sec.	
Control output	Relay contact (-R/ \square)	1a, control capacity : 220Vac 3A (resistive load) 220Vac 1A (inductive load $\cos\phi = 0.4$)	
	Non-contact voltage (-S/ \square)	15Vdc (Load resistance: 250 Ω to 1.2k Ω .)	
	DC current (-A/ \square)	4 to 20mAdc, Load resistance: 600 Ω max.	
	ON/OFF servo (-15 \square -R/ \square)	Control output: Relay contact output 1c Dead band: 0 to 100.0% of proportional band Feedback resistance: 100 Ω to 10k Ω	
Alarm action (A1)	Kinds	High limit alarm	settable: \pm (scaling range span)
		Low limit alarm	settable: \pm (scaling range span)
		High/Low limit alarm	settable: 1 to Scaling range span
		High/Low limit range alarm	settable: 1 to Scaling range span (Setting the value to 0 disables the function)
	Process value alarm	settable: Scaling from low to high limit setting value	
Setting accuracy	The same as main setting.		
Action	ON/OFF action, Dead band : 0 to 999 (DC voltage or current) 0 to 99.9 or 0 to 99 (Thermocouple or RTD)		
Output	Relay contact 1a, Control capacity: 220Vac 0.5A (resistive) 220Vac 0.2A (inductive, $\cos\phi = 0.4$)		
Dielectric strength	Input terminal-Ground terminal 500Vac for 1 min. Power terminal-Ground terminal 1.5kVac for 1 min. Output terminal-Ground terminal 1.5kVac for 1 min. (However, voltage must not be applied to the output terminal for -S/ \square , -A/ \square .)		
Insulation resistance	10M Ω or more at 500Vdc	Sampling period	0.1 sec. (If option External setting or Cascade control is applied, it turns to 0.2sec.)
Supply voltage	85 to 264Vac, 50/60Hz		
Power consumption	Approx. 15W	Mounting method	Flush
Instantaneous power failure	Within 30ms	Panel case	Material: Incombustible resin Color: Black
Ambient temperature	0 to 50 $^{\circ}$ C (32 to 122 $^{\circ}$ F)	Weight	Approx. 1kg
Ambient humidity	35 to 85% RH (non-condensing)	Accessories	Mounting bracket: 1 set Unit nameplate: 1 sheet Instruction manual: 1 copy Memory-card: 1 sheet (When External memory function (DM) is applied.)

■ Optional specifications

Optional name	Code	Description
Alarm output A1 with standby	H	The standby alarm function disables alarm action until the input value passes over the alarm setpoint on initial start.
Alarm output A2	AL \square	The same as A1 alarm, the setting is deviation setting (\pm) against main setting, and when the input value exceeds the setting range, the output turns ON.
Alarm output A2 with standby	AL \square H	An alarm output with standby to A2 output. The specification is the same as the A1 output.
Alarm output A3 and A4	SA	An alarm outputs using the open collectors. The kinds of alarms are the same as A1 one.
Heating and cooling control output	D \square *1	It allows to control heating (main control) and cooling (sub-control) simultaneously. [Relay contact: DR, Non-contact voltage: DS, DC current: DA]
Transmitting output	SVT \square PVT \square MVT \square FPT \square	It outputs each setting value converting the value to analog signal (4 to 20mAdc or 0 to 1Vdc). SV transmission 4 to 20mAdc, code: A, 0 to 1Vdc, code: V PV transmission 4 to 20mAdc, code: A, 0 to 1Vdc, code: V MV transmission 4 to 20mAdc, code: A, 0 to 1Vdc, code: V Feedback potentiometer position transmission (Only for HCD-150) 4 to 20mAdc, code: A, 0 to 1Vdc, code: V
Serial communication	C5 C	Using the communicating circuit RS-485 (C5) and RS-232C (C), it can set various parameter and read the data of control status. (1)Reading and setting of the values such as main setting, PID and ARW. (2)Reading of input value and action status. (3)Change of the functions.
Setting value external change	SM	Changing the external terminal connection by remote control, it can select the setting value memory number, and can change the Auto/Manual. If option E is applied together with this option, Remote/Local can be changed as well.
Status output	SO	The statuses sensor burnout, remote and manual can be confirmed by open collector output.
External memory function	DM or DMO	Using the memory-card, 14 kinds of setting values can be written or read in 15 files. In case the memory-card is not required, specify "DMO". (Card memory capacity: 32kilo-byte)
External setting	EA or EV *2	When remote setting, the main setting value can be set by external analog signal. To select the signal level, it is performed with the front key. 4 to 20mAdc, 0 to 20mAdc code: EA 0 to 1Vdc, 0 to 10Vdc, 1 to 5Vdc code: EV
Cascade control	CC*1 *2	HCD-100 allows cascade control with one controller. Calculates the input 1 as primary controller input and input 2 as secondary one.
Security function	SE	It allows to lock the setting values by the security code. However, if this function is applied, the setting value lock function cannot be used.

As for the specifications marked *1 or *2, they cannot be applied with another specification which has the same mark. For the type ON-OFF servo, the option marked *1 cannot be applied.

Application

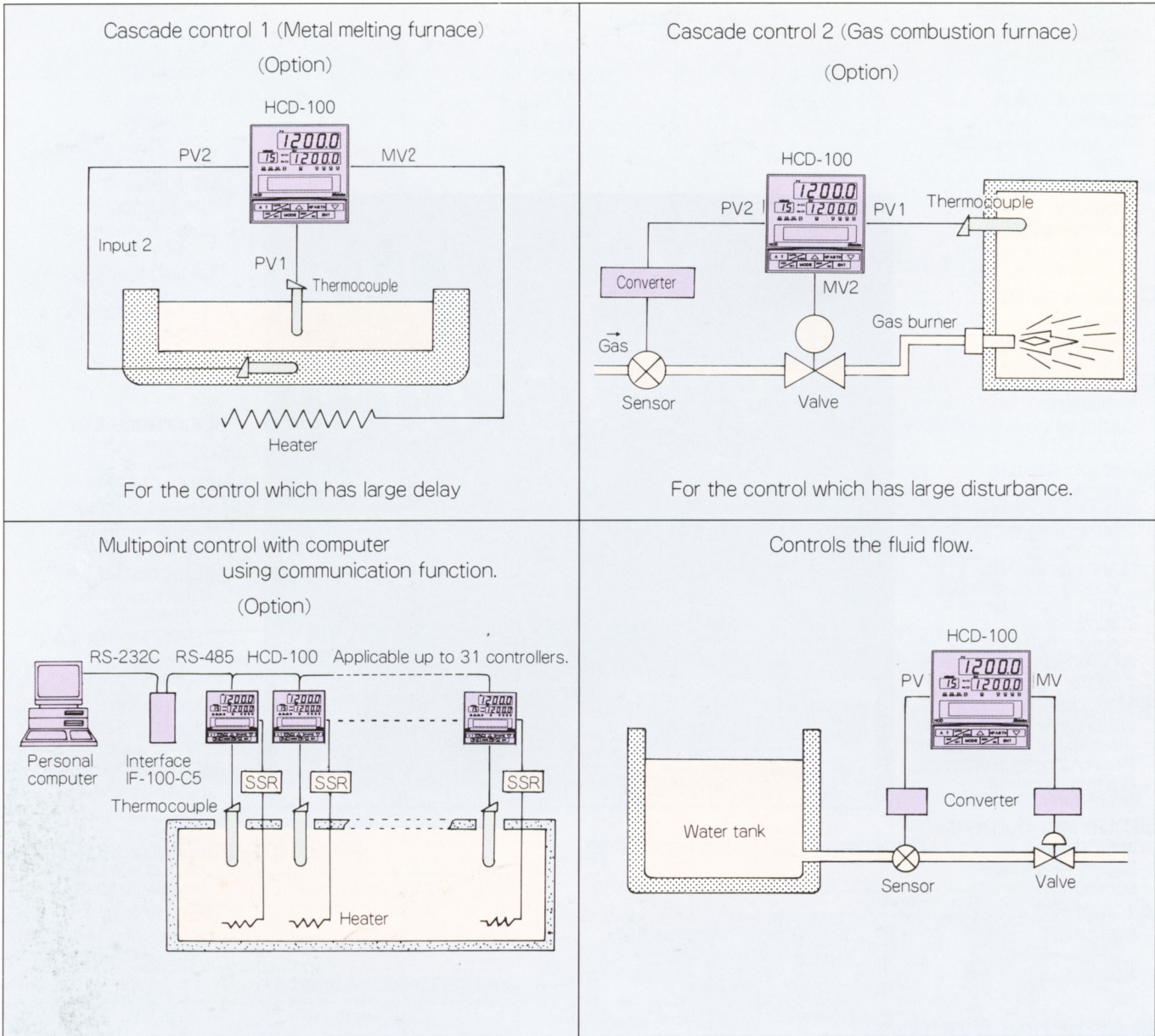

External dimensions

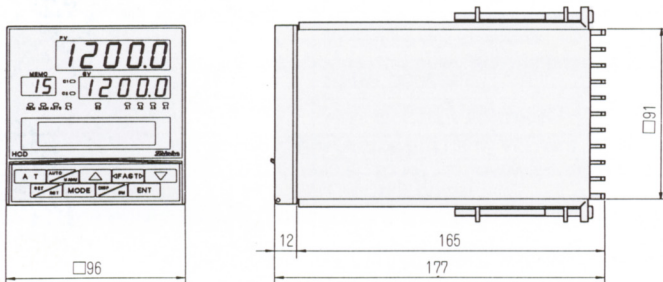

Panel cutout

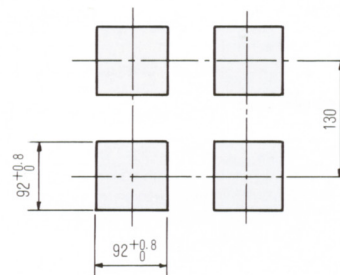

- The contents of this catalog is as of November 1999. Specifications subject to change without notice.
- For any inquiry of this controller, please contact your shop where purchased or our agency.

SHINKO TECHNOS CO., LTD. OVERSEAS DIVISION

Reg. Office : 2-48, 1-Chome, Ina, Minoo, Osaka, 562-0015, Japan
 Mail Address: P. O. Box 17, Minoo, Osaka, Japan
 Cable : SHINKO MINOO JAPAN
 Tel : 81 - 727 - 21 - 2781
 Fax : 81 - 727 - 24 - 1760
 URL : <http://www4.osk.3web.ne.jp/~shinkood/>
 e-mail : shinkood@osk2.3web.ne.jp