

ACS-13A



A Superior, Smaller Controller

Shinbo

Point 1 Controller with the shortest depth (56mm)

Higher functions and performance have been achieved with the shortest depth of 56mm ACS-13A. This provides cost and space reduction.



Actual size

Please use a gasket to reinforce Dust-proof/Drip-proof function.
Depth of control panel interior when gasket is used: 54.5mm

The shortest depth

56mm

Point 2 An easier viewing display with status color indication

The PV display color can be selected from red, green and orange.

The PV display color can also change continuously depending on deviation between PV and SV, which allows easy and distinct status checking.



PV display color

- Regular status: Green
- Regular status: Red
- Regular status: Orange
- Alarm OFF: Green, Alarm ON: Red
- Alarm OFF: Orange, Alarm ON: Red
- PV color changes continuously :
Orange → Green → Red
- PV color changes continuously + Alarm ON (Red)

- PV color continuous change mode

PV is higher than [SV+PV color range]



PV is within [SV±PV color range]



PV is lower than [SV-PV color range]



- Alarm color (when setting High/Low limits alarm)



Low limit alarm active



Regular status



High limit alarm active

It is easier to see the SV and PV, using an 11-segment LCD display.



All segments
backlit



SENS



A1LM

Point 3 Versatile controls, specifications and enhancements

4-point SV, using external selection

SV memory function, which can switch 4 points of SV using external contact signal, is equipped. After registering the SVs (from SV1 to SV4), they can be easily switched by external operation.

3-phase Heater burnout alarm

Any trouble in 3-phase heaters such as burnout or deterioration can be detected by connecting 2 CTs (current transformers).

Alarm types 20A and 50A are available for both single phase and 3-phase.

Point 4 User friendly communication: Remote monitoring, data transmission

Standard Console communication function enables 1 to 1 communication between a PC with USB port and the ACS-13A. Various settings and monitoring can be performed using the Console software SWS-ACS01M. SWS-ACS01M is attached to the USB communication cable CMA (sold separately).



USB communication cable CMA

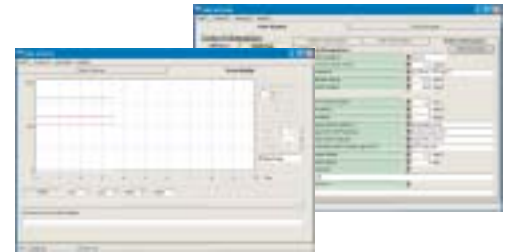
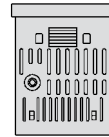

Displays of the Console software (SWS-ACS01M)

Optional Serial communication (RS-485)

Serial communication (RS-485) between a PC/Touch panel unit and the ACS-13A enables various settings and remote monitoring. A maximum of 31 units in a centralized control system can be established. Shinko protocol and Open Network Modbus protocol are usable.

When monitoring multiple ACS-13A units with a PC or Touch panel unit

By connecting to the Touch panel unit, up to 31 points of temperature control can be easily monitored.

For a PC with RS-232C, a communication converter is required.

Touch panel units corresponding to the ACS-13A are as shown below.

Digital Electronics Corp. : GLC series, GP series

Hakko Electronics Co., Ltd. : V7 series, V6 series

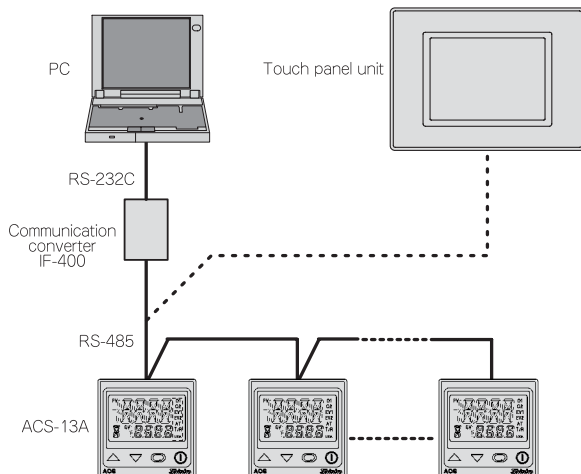

When communicating with a PLC and up to 32 units of the ACS-13A

By connecting to a PLC via PLC interface unit SIF-400, up to 32 units of the ACS-13A can be connected.

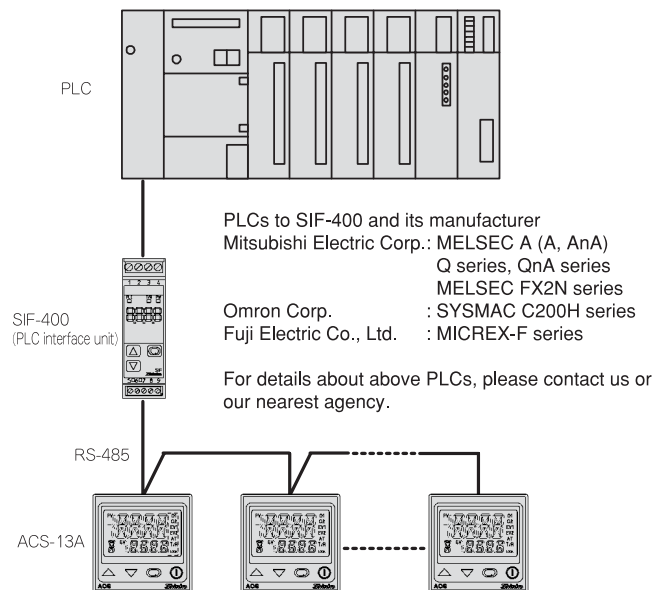

Point 5 Dust-proof/Drip-proof function (IP66)

- Can be used in a dust or water splashed environment.
- UL/C-UL pending

Point 6 Output rate of change limit

This function is suitable for heaters which are not designed for sudden changes in output (OUT1). This is suited for controlling heaters such as the Kanthal Super. This also stabilizes control by suppressing output fluctuation.

Name and functions of the sections

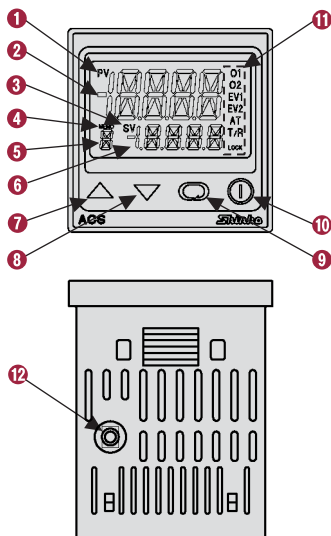

- ① PV indicator : Lights when the PV is indicated in the PV/SV display mode.
- ② PV display : Indicates the PV (process variable).
- ③ SV indicator : Lights when the SV is indicated in the PV/SV display mode.
- ④ MEMO indicator : Lights when Set value memory external selection (SM option) is added.
- ⑤ MEMO display : Indicates the Set value memory number.
- ⑥ SV display : Indicates the SV (set value).
- ⑦ Increase key : Increases the numeric value.
- ⑧ Decrease key : Decreases the numeric value.
- ⑨ Mode key : Selects the setting mode, or registers the set value.
To register the set (selected) value, press this key.
- ⑩ OUT/OFF key : Switches control output ON/OFF or Auto/Manual control function.
- ⑪ Action indicators
 - 01(OUT1): Lights when control output is ON or when Heating output (D□ option) is ON.
 - 02(OUT2): Lights when Cooling output (D□ option) is ON.
 - EV1 : Lights when Alarm 1 output is ON.
 - EV2 : Lights when Alarm 2 output (A2 option) is ON or when Heater burnout alarm (W, W3 option) is ON.
 - AT : Flashes while AT (auto-tuning) or auto-reset is performing.
 - T/R : Lights when Serial communication (C5 option) is performing (TX output).
 - LOCK : Lights when Lock 1, Lock 2 or Lock 3 is selected.
- ⑫ Console connector: The following operations can be conducted by connecting to the USB communication cable (Model: CMA, sold separately). (1) Reading and setting of SV, PID and various set values, (2) Reading of PV and action status and (3) Function change

Model name

ACS-1 3A <input type="checkbox"/> / <input type="checkbox"/> <input type="checkbox"/> <input type="checkbox"/> <input type="checkbox"/> <input type="checkbox"/>		ACS-13A (W48×H48×D62mm)	
Control output (OUT1)	R	Relay contact 1a	
	S	Non-contact voltage (for SSR drive)	
	A	DC current	
Input	M	Multi-input	
		100 to 240V AC*	
Supply voltage		24V AC/DC	
	1	Alarm 2	
Option	A2	Alarm 2	
	C5	Serial communication (EIA RS-485)	
	DR	Heating/Cooling control (relay output)	
	DS	Heating/Cooling control (SSR output)	
	SM	Set value memory external selection	
	W (20A)	Rated current: Single phase 20A	Heater burnout Alarm
	W (50A)	Rated current: Single phase 50A	
	W3 (20A)	Rated current: 3-phase 20A	
W3 (50A)	Rated current: 3-phase 50A		

Designate the specification from the columns.

* For the power supply voltage, 100 to 240V AC is standard, however, when ordering 24V AC/DC, enter "1" after the input code.

When adding options, punctuate them with a comma.

- If A2 option is specified, DR or DS option cannot be added.
- If C5 option is specified, SM option cannot be added.
- If option is specified, A2, W or W3 option cannot be added.
- If W or W3 option is specified, DR or DS option cannot be added.
- For DC current output type, W or W3 option cannot be added.

Rated range (Full multi-range)

Input type		Input range	
Thermocouple	K	-200 to 1370 °C	-320 to 2500 °F
		-200.0 to 400.0 °C	-320.0 to 750.0 °F
	J	-200 to 1000 °C	-320 to 1800 °F
		0 to 1760 °C	0 to 3200 °F
	S	0 to 1760 °C	0 to 3200 °F
		0 to 1820 °C	0 to 3300 °F
	B	0 to 1820 °C	0 to 3300 °F
		-200 to 800 °C	-320 to 1500 °F
	T	-200.0 to 400.0 °C	-320.0 to 750.0 °F
		-200 to 1300 °C	-320 to 2300 °F
PL- II	0 to 1390 °C	0 to 2500 °F	
	C(W/Re5-26)	0 to 2315 °C	0 to 4200 °F
RTD	Pt100	-200 to 850 °C	-320 to 1500 °F
		-200.0 to 850.0 °C	-320.0 to 1500.0 °F
	JPt100	-200 to 500 °C	-320 to 900 °F
		-200.0 to 500.0 °C	-320.0 to 900.0 °F
DC current	4 to 20mA DC	-2000 to 10000	
	0 to 20mA DC		
DC voltage	0 to 1V DC		
	0 to 10V DC		
	1 to 5V DC		
	0 to 5V DC		

• For DC current and voltage input, scaling and decimal point place change are possible.

• For DC current input, connect 50 Ω shunt resistor (sold separately) between input terminals.

Standard specifications

Display	<p>PV display ----- 11-segment Backlight LCD Red/ Green /Orange, Character size, 12.0 x 5.4mm (H x W)</p> <p>SV display ----- 11-segment Backlight LCD Green, Character size, 6.0 x 3.5mm (H x W)</p> <p>MEMO display ---- 11-segment Backlight LCD Green, Character size, 4.8 x 2.8mm (H x W)</p> <p>Indicators-- Backlight Orange</p>
Input	<p>Thermocouple ---- K, J, R, S, B, E, T, N, PL-II , C (W/Re5-26) External resistance: 100 Ω or less, however, for B input, 40 Ω or less</p> <p>RTD----- Pt100, JPt100 3-wire system (Allowable input lead wire resistance: 10 Ω or less per wire)</p> <p>DC current----- 0 to 20mA DC, 4 to 20mA DC: Input impedance: 50 Ω (50 Ω shunt resistor must be connected between input terminals.) Allowable input current: 50mA DC or less (when 50 Ω shunt resistor is used)</p> <p>DC voltage----- 0 to 1V DC: Input impedance 1M Ω or more Allowable input voltage: 5V DC or less, Allowable signal source resistance: 2k Ω or less 0 to 5V DC, 1 to 5V DC, 0 to 10V DC: Input impedance: 100k Ω or more, Allowable input voltage: 15V DC or less Allowable signal source resistance: 100 Ω or less</p>
Accuracy (Setting·Indication)	<p>Thermocouple----- Within ±0.2% of each input span ±1digit, or within ±2°C (4°F), whichever is greater However, R, S input, the range is 0 to 200°C (0 to 400°F): Within ±6°C (12°F) B input, the range is 0 to 300°C (0 to 600°F): The accuracy is not guaranteed. K, J, E, T, N input, less than 0°C (32°F): Within ±0.4% of input span ±1digit</p> <p>RTD----- Within ±0.1% of each input span±1digit, or within ±1°C (2°F), whichever is greater</p> <p>DC current, DC voltage -- Within ±0.2% of each input span±1digit</p>
Input sampling period	0.25sec.
Control output (OUT1)	<p>Relay contact ----- 1a, control capacity: 3A 250V AC (resistive load), 1A 250V AC (inductive load cos φ=0.4), Electric life: 100,000 times</p> <p>Non-contact voltage -- 12V DC±15% Max. 40mA DC (short circuit protected)</p> <p>DC current ----- 4 to 20mA DC load resistance: Max. 550 Ω</p>
Control action	<p>The following actions can be selected by keypad. (Default value: PID)</p> <p>PID (with auto-tuning function), PI, PD (with auto-reset function), P (with auto-reset function), ON/OFF</p> <p>OUT1 proportional band (P) ----- 0 to 1000°C (2000°F), 0.0 to 1000.0°C (°F), or 0.0 to 100.0% (ON/OFF action when set to 0 or 0.0)</p> <p>Integral time (I) ----- 0 to 1000 seconds (Off when set to 0)</p> <p>Derivative time (D) ----- 0 to 300 seconds (Off when set to 0)</p> <p>OUT1 ON/OFF action ----- When set the proportional band to 0 or 0.0</p> <p>OUT1 proportional cycle ----- 1 to 120 seconds (Not available for DC current output type)</p> <p>ARW ----- 0 to 100%</p> <p>OUT1 ON/OFF action hysteresis --- 0.1 to 100.0°C (°F) or 1 to 1000</p> <p>OUT1 high limit setting ----- 0 to 100% (DC current: -5 to 105%)</p> <p>OUT1 low limit setting ----- 0 to 100% (DC current: -5 to 105%)</p>
Alarm 1 output	<p>Alarm types can be selected by keypad. (Default: No alarm action)</p> <ul style="list-style-type: none"> - No alarm action - High limit alarm (Deviation setting) Setting range: —(Input span) to Input span - Low limit alarm (Deviation setting) Setting range: —(Input span) to Input span - High/Low limits alarm (Deviation setting) Setting range: 0 to Input span - High/Low limit range alarm (Deviation setting) Setting range: 0 to Input span - Process high alarm Setting range: Input range low limit value to Input range high limit value - Process low alarm Setting range: Input range low limit value to Input range high limit value - High limit alarm with standby (Deviation setting) Setting range: —(Input span) to Input span - Low limit alarm with standby (Deviation setting) Setting range: —(Input span) to Input span - High/Low limits alarm with standby (Deviation setting) Setting range: 0 to Input span <p>When input is DC current or DC voltage, the input span is the same as the scaling span. When input is DC current or DC voltage, the input range low (or high) limit value is the same as the scaling low (or high) limit value.</p> <p>Setting accuracy----- The same as the indication accuracy</p> <p>Action----- ON/OFF action</p> <p>Hysteresis----- 0.1 to 100.0°C (°F) or 1 to 1000</p> <p>Output----- Relay contact 1a, Control capacity: 3A 250V AC (Resistive load), 1A 250V AC (Inductive load cos φ=0.4), Electric life: 100,000 times</p>
Supply voltage	<p>100 to 240V AC 50/60Hz, 24V AC/DC 50/60Hz</p> <p>Allowable voltage fluctuation range: 85 to 264V AC, 20 to 28V AC/DC</p>
Power consumption	Approx. 8VA
Insulation resistance	10M Ω or more, at 500V DC
Dielectric strength	Between Input terminal-Power terminal. Between Output terminal-Power terminal ----- 1.5kV AC for 1 minute
Environment	Ambient temperature: 0 to 50°C Ambient humidity: 35 to 85%RH (non-condensing)
Case, Material, Color	Material: Flame resistant resin Color: Black
Mounting method	Mounting frame (Mountable control panel thickness: 1 to 5mm)
Setting method	Sheet key input
External dimensions	W48 x H48 x D62mm (Depth of control panel interior when gasket is used: 54.5mm)
Weight	Approx. 120g
Attached functions	Power failure countermeasure, Self-diagnosis, Automatic cold junction temperature compensation (only for thermocouple), Burnout, Input abnormality indication, Indication range, Control range, Warm-up indication, Auto/Manual control switching, Console communication
Accessories included	<p>Mounting frame 1 piece, Gasket (Front mounted to the ACS-13A) 1 piece</p> <p>Instruction manual (A3 unfolded, English/Japanese) 1 copy</p> <p>CT (Current transformer): CTL-6S: 1 piece [W (20A) option] CTL-12-S36-10L1: 1 piece [W (50A) option]</p> <p>CTL-6S: 2 pieces [W3 (20A) option] CTL-12-S36-10L1: 2 pieces [W3 (50A) option]</p>
Accessories sold separately	Terminal cover, 50 Ω Shunt resistor (DC current input), USB communication cable CMA to which the Console software SWS-ACS01M is attached

Optional specifications

Please specify options according to the users' needs. When ordering, specify an option code to be applied.

Alarm 2 output [A2]	Alarm type, Setting range and output type, etc. are the same as those of Alarm 1. See Alarm 1 output section. If this option is applied, Heating/Cooling control (D□ option) cannot be added. This option and Heater burnout alarm (W, W3 option) utilize common output terminals.																				
Heater burnout alarm [W, W3] (CT included)	Rating ----- Single phase 20A [W(20A)], Single phase 50A [W(50A)], 3-phase 20A [W3(20A)], 3-phase 50A [W3(50A)] Must be specified. Setting range----- Rated current 20A [W(20A), W3(20A)]: 0.0 to 20.0 A Rated current 50A [W(50A), W3(50A)]: 0.0 to 50.0 A Setting accuracy ---- Within ±5% of the rated value Action ----- ON/OFF action Output ----- Relay contact 1a, Control capacity: 3A 250V AC (resistive load), 1A 250V AC (inductive load $\cos\phi=0.4$), Electric life: 100,000 times If this option is added, Heating/Cooling control (D□ option) cannot be added.																				
Heating/Cooling control [D□]	Heating control action: The same as the control output (OUT1) Cooling control action OUT2 proportional band (P) --- 0.0 to 10.0 times the control output (OUT1) proportional band (ON/OFF action when set to 0.0) OUT2 integral time (I) ----- The same as that of the control output (OUT1) OUT2 derivative time (D) ----- The same as that of the control output (OUT1) OUT2 proportional cycle ----- 1 to 120 seconds Overlap/Dead band ----- Thermocouple, RTD: -100.0 to 100.0°C (°F) DC current, DC voltage: -1000 to 1000 (The placement of the decimal point follows the selection) OUT2 hysteresis ----- Thermocouple, RTD : 0.1 to 100.0°C (°F) OUT2 action mode ----- One cooling action can be selected from Air cooling (linear characteristic), Oil cooling (1.5th power of the linear characteristic) and Water cooling (2nd power of the linear characteristic) by keypad. Output ----- Relay contact 1a, Control capacity: 3A 250V AC (resistive load), 1A 250V AC (inductive load $\cos\phi=0.4$), Electric life: 100,000 times Non-contact voltage 12V DC ±15% Max. 40mA DC (short circuit protected) If this option added, Alarm 2 (A2 option) and Heater burnout alarm (W, W3 option) cannot be added.																				
Serial communication [C5]	Various operations such as Reading and setting of various set values, Reading of PV and action status and Function change can be performed from the external PC. Communication interface ----- EIA RS-485 Communication system ----- Half-duplex communication start-stop synchronous Communication speed----- 2400/4800/9600/19200bps (Can be selected by keypad) Data bit /Parity ----- Data bit: 7or 8, Parity: Even/Odd /No parity (Can be selected by keypad) Stop bit ----- 1 or 2 (Can be selected by keypad) Communication protocol ----- Shinko/Modbus RTU/Modbus ASCII (Can be selected by keypad) Number of connectable units ----- Max. 31 units per host computer Communication error detection -- Parity, checksum, LRC (Modbus ASCII), CRC-16 (Modbus RTU) Data format <table border="1"> <thead> <tr> <th>Communication protocol</th> <th>Shinko protocol</th> <th>Modbus ASCII</th> <th>Modbus RTU</th> </tr> </thead> <tbody> <tr> <td>Start bit</td> <td>1</td> <td>1</td> <td>1</td> </tr> <tr> <td>Data bit</td> <td>7</td> <td>7 or 8</td> <td>8</td> </tr> <tr> <td>Parity</td> <td>Yes (Even)</td> <td>Yes (Even, Odd) No parity</td> <td>Yes (Even, Odd) No parity</td> </tr> <tr> <td>Stop bit</td> <td>1</td> <td>1 or 2</td> <td>1 or 2</td> </tr> </tbody> </table> If this option is added, Set value memory number external selection (SM option) cannot be added.	Communication protocol	Shinko protocol	Modbus ASCII	Modbus RTU	Start bit	1	1	1	Data bit	7	7 or 8	8	Parity	Yes (Even)	Yes (Even, Odd) No parity	Yes (Even, Odd) No parity	Stop bit	1	1 or 2	1 or 2
Communication protocol	Shinko protocol	Modbus ASCII	Modbus RTU																		
Start bit	1	1	1																		
Data bit	7	7 or 8	8																		
Parity	Yes (Even)	Yes (Even, Odd) No parity	Yes (Even, Odd) No parity																		
Stop bit	1	1 or 2	1 or 2																		
Set value memory external selection [SM]	SV1, SV2, SV3 or SV4 can be selected by the external contact. The MEMO display indicates the selected memory number. Contact input terminals DI2 can be used for "Set value memory external selection" or for "OUT/OFF external selection" during the "Contact input function selection" of the Setup mode. If Auto/Manual control function is selected during "OUT/OFF key function selection" in the Setup mode, externally Auto/Manual control can be switched. Circuit current when closed: Approx. 6mA If this option is added, Serial communication (C5 option) cannot be added.																				

Terminal arrangement

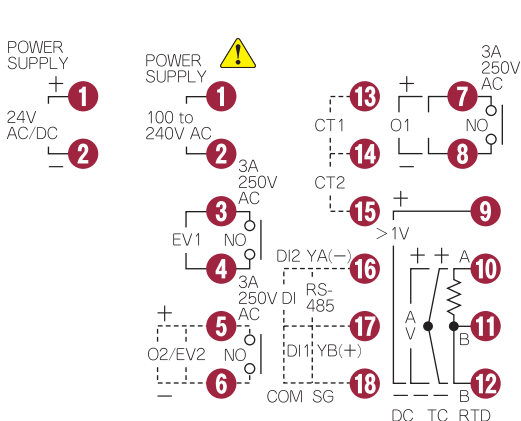

POWER SUPPLY

EV1

Alarm 1 output

O2/EV2

Cooling output (Option: D□), Alarm 2 output (Option: A2) or Heater burnout alarm output (Option: W, W3)

O1

Control output or Heating output (Option: D□)

DC

DC current or DC voltage input (For DC voltage input, + side terminal number differs depending on the voltage input.)

TC

Thermocouple input

RTD

RTD input

CT1

CT input 1 (Option: W, W3)

CT2

CT input 2 (Option: W3)

DI

Contact input (Option: SM)

RS-485

Serial communication RS-485 (Option: C5)



- This controller does not have built-in power switch, circuit breaker or fuse. It is necessary to install them near the controller.
- For a 24V AC/DC power source, do not confuse polarity when using direct current (DC).

Solderless terminal

Use a solderless terminal with an insulation sleeve in which the M3 screw fits. Tightening torque is 0.6N·m to 1.0N·m.

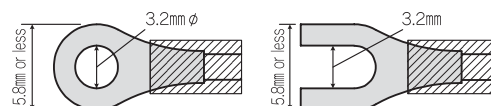

External dimensions (Unit: mm)

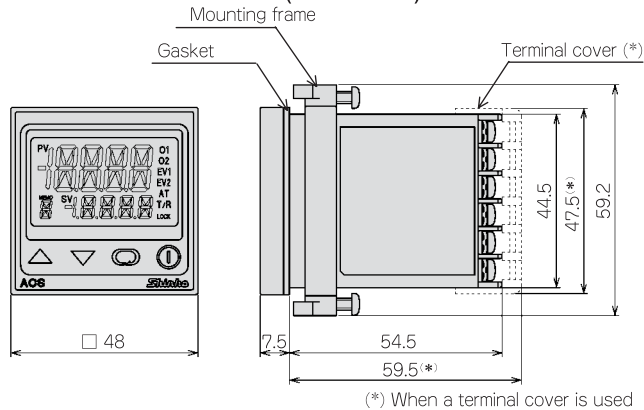

Panel cutout (Unit: mm)

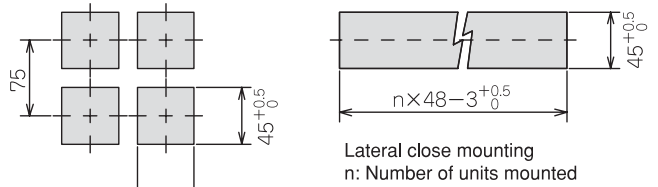

Caution:

If lateral close mounting is used for the controller, IP66 specification (Dust-proof/Drip-proof) may be compromised, and all warranties will be invalidated.

Wiring example

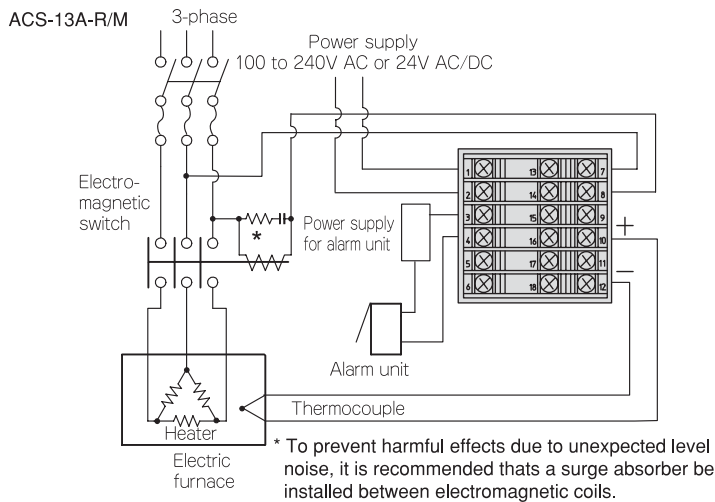

CT external dimensions (Unit: mm)

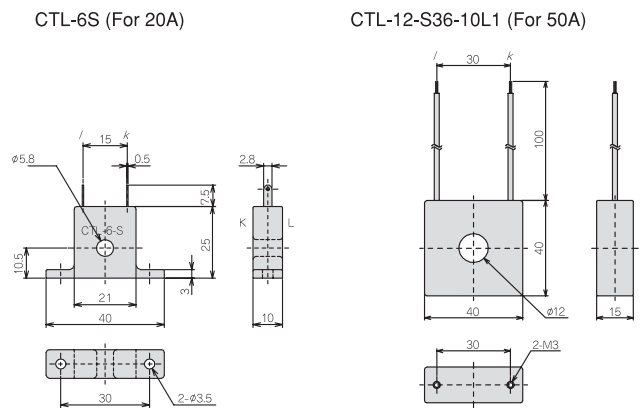

Console software SWS-ACS01M included

Using the Console software with an USB communication cable CMA (sold separately), parameters setting, logging and monitoring of the controller can be performed by connecting to the USB port of the PC.

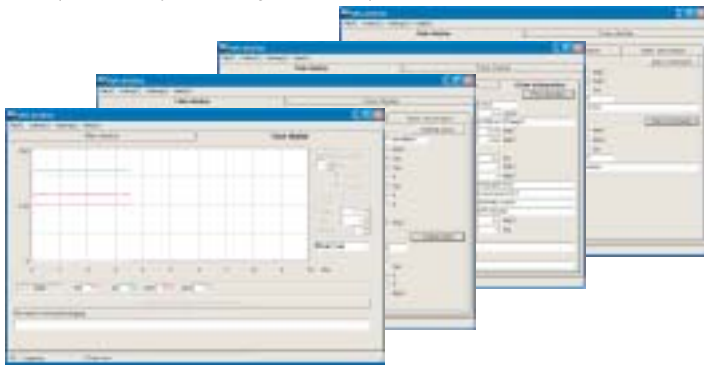

USB communication cable CMA (Unit: mm)

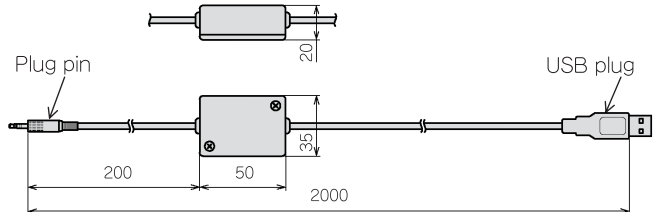

SAFETY PRECAUTIONS

- To ensure safe and correct use, thoroughly read and understand the manual before using this instrument.
- This instrument is intended to be used for industrial machinery, machine tools and measuring equipment. Verify correct usage after consulting purpose of use with our agency or main office. (Never use this instrument for medical purposes with which human lives are involved.)
- External protection devices such as protection equipment against excessive temperature rise, etc. must be installed, as malfunction of this product could result in serious damage to the system or injury to personnel. Also proper periodic maintenance is required.
- This instrument must be used under the conditions and environment described in the manual. Shinko Technos Co., Ltd. does not accept liability for any injury, loss of life or damage occurring due to the instrument being used under conditions not otherwise stated in the manual.

Caution with respect to Export Trade Control Ordinance

To avoid this instrument from being used as a component in, or as being utilized in the manufacture of weapons of mass destruction (i.e. military applications, military equipment, etc.), please investigate the end users and the final use of this instrument. In the case of resale, ensure that this instrument is not illegally exported.



· This catalog is as of November 2005 and its contents are subject to change without notice.
 · If you have any inquiries, please consult us or our agency.

SHINKO TECHNOS CO., LTD. OVERSEAS DIVISION

Reg. Office : 2-5-1, Senbahigashi, Minoo, Osaka, 562-0035, Japan
 Tel : 81 - 72 - 727 - 6100
 Fax : 81 - 72 - 727 - 7006
 URL : <http://www.shinko-technos.co.jp>
 E-mail : overseas@shinko-technos.co.jp